

UV MEDIUM PRESSURE SYSTEM

Design, Installation, Operation and
Maintenance Guide
AUV Series





CAUTION

Read the manual in its entirety. This manual contains essential information about the installation, operations, maintenance, and safe use of this product. Equipment must be installed and serviced by a qualified technician. Improper installation can void the warranty and cause bodily injury. All weights and dimensions are approximate. All dimensions are in inches; all weights are in pounds.

For all questions, please contact Aquify Systems or a certified Aquify Systems Support Agent.

****NOTE:**** Although every effort has been made to ensure that this manual provides up-to-date information, please note that Aquify Systems by UltraAqua's UV-specifications are subject to change without notice. Aquify shall not be liable for the accuracy of any information provided by third party technical support personnel, or any damage caused, directly or indirectly, by acts taken or omissions made by you because of such technical support.



IMPORTANT!



WARNING UV RAYS! PROTECT BOTH EYES AND SKIN.

HIGH VOLTAGES ARE PRESENT ON LAMP CONNECTORS AND CABLES! THE ELECTRONIC LAMP DRIVERS MAY ONLY BE INSTALLED AND OPERATED BY QUALIFIED AND TECHNICALLY TRAINED PEOPLE.



PLEASE WEAR GLOVES WHEN HANDLING UV LAMPS AND QUARTZ SLEEVES, AS COMPOUNDS FROM SKIN WILL DECREASE UV ENERGY TRANSMISSION AND MAY LEAD TO PREMATURE FAILURE.

TO AVOID FIRE, ELECTRIC SHOCK AND PERSONAL INJURY DO NOT EXPOSE ELECTRIC PARTS TO WATER OR MOISTURE.



CORROSIVE AMBIENT AIR WILL DESTROY ELECTRICAL COMPONENTS AND VOID WARRANTY.



ACCUMULATION OF AIR INSIDE REACTOR CHAMBER WILL REDUCE EFFICIENCY. TO AVOID HEAT DAMAGES, REACTOR CHAMBER MUST BE INSTALLED IN SUCH A WAY THAT AIR CANNOT ACCUMULATE, AND THE REACTOR IS COMPLETELY WATER FILLED DURING OPERATION.

ALWAYS DEPRESSURIZE CHAMBER BEFORE PERFORMING PROCEDURES INVOLVING LAMPS, QUARTZ OR SENSOR HOUSING.

ALWAYS USE GLOVES WHEN HANDLING
UV LAMPS AND QUARTZ SLEEVES

ALWAYS INSTALL REACTOR CHAMBER WITH UV-LAMP(S) IN HORIZONTAL POSITION.

IN THE EVENT OF AN EMERGENCY!

SWITCH OFF POWER OR DISCONNECT POWER FROM THE MAIN POWER SUPPLY. IN CASE OF WATER LEAKAGE, SHUT DOWN WATER FLOW THROUGH THE UV AND DEPRESSURIZE THE CHAMBER.

TABLE OF CONTENTS

INTRODUCTION	2
Receiving the Equipment	3
SAFETY INFORMATION	4
Confirm the Following	4
SAFETY INSTRUCTIONS	5
UV Reactor	5
Control Cabinet	5
Input Signals	6
Installation Check List	6
GENERAL OVERVIEW	7
UV Selection and Design	8
Flow Specification	9
Technical Specification	10
Installation of UV Reactor	11
CONTROL CABINET	13
Technical Specifications	14
UV CHAMBER	15
Reactor Body	15
UV Lamps	15
Replacement of UV-Lamps	16
Removing Broken Lamps and Quartz	17
Quartz Sleeves	18
Wiper System	19
Replacement of Spindle Seal	20
Replacement of Wiper Ringer	21
Bottom Plate	22
Temperature Sensor and Switch	22
UV Sensor	23
Winterization	23
Sacrificial Anode	24
Witches Hat Strainer	25
OPERATIONAL CONTROL	26
Control Start-Up	26
Start-Up Wizard	26



First Lamp Start-Up	29
Stop the UV System	30
Control System Preparation	30
Set UVI 100% Reference	30
Password Access	30
Set System Time	30
CONTROL PANEL MENUS	31
HMI Navigation	31
Set System Time	31
Home Screen	32
Set-Up – Operation Screen	33
Set-Up – Time Schedule	34
Set-Up – Temperature Screen	35
Set-Up – UV Sensor Screen	36
Set-Up – UV Dose Screen	37
Set-Up – Analogue Flow	38
Set-Up – Analogue Output	39
Set-Up – Analogue UVT	40
Analogue Combined Chlorine	41
Set-Up – System Relays	42
Set-Up – Wiper	43
Status – Overview Screen	46
Status – Driver Screen	47
Log – Logging Screen	48
Log – Event Log Screen	49
Log – Power Screen	50
Log – Diagnostics Screen	51
Log – Wiper Current	52
Service – UV Lamps	53
Service – Quartz Sleeves	54
Service – UV Sensor	55
Service – Wiper	56

TROUBLESHOOTING	57
ALARM TABLE	58
ERROR & WARNINGS	60
MAINTENANCE	61
DISPOSABLE	62
MAINTENANCE TABLE	63
SPARE PARTS	64
TESTING AND COMMISSIONING – SIGN OFF	67
EQUIPMENT WARRANTY	68
LAMP WARRANTY	70
ANNEX	72
Validation Specification:	72

INTRODUCTION

Ultraviolet (UV) technology has a long history of over 100 years and has since then experienced a thorough utilization of the technology's potential. Today, UV disinfection is recognized as an effective method in a wide range of water qualities and applications. Improved technological and design configurations have made UV a viable OPEX and CAPEX solution for disinfection processes, as well as in more advanced applications such as an Advanced Oxidation Processes (AOP).

The sustainable method is based on the natural disinfection action of the sun's rays. UV systems produce the same ultraviolet germicidal rays through their UV lamps, just thousands of times stronger. No bacteria, viruses, molds, or spores are able to withstand this water treatment path, making UV technology a globally accepted solution for water disinfection.

The use of UV technology effectively ensures that the water quality, both physical and chemical, remains identical before and after the treatment. Additionally, the reaction time between the UV irradiation and the organism to be inactivated is very short and creates no by-products. These are some of the advantages that make UV technology systems the preferred solution in a wide range of water treatment applications.

The radiation dose or fluence is a design parameter for the disinfection effect of UV irradiation. The necessary dose to achieve a given inactivation depends on the organism to be killed. The measurement is expressed in mWs/cm^2 and/or mJ/cm^2 .

UV Transmission (UVT) measures the capacity of UV light to penetrate through 1 cm of liquid. When UV light irradiates water, some of the radiation is absorbed by the water, reducing the light intensity emitted from the lamp. The Aquify UV system by UltraAqua is specifically designed with this in mind, ensuring optimal UV output despite potential UVT variations. The system is easy to install and maintain and is thoroughly cost-optimized, providing an efficient and budget-friendly solution to improve water quality of the commercial aquatic application.



Receiving the Equipment

Unpack your Aquify UV-system.

Make sure all components are free from damage.

Take pictures and contact Aquify immediately if any damage is observed.

Your shipment should contain the following parts:

- UV reactor
- Electrical control cabinet
- Cable
- Electrical wiring diagram (inside control cabinet)
- Warning labels and cleaning sponge
- Ordered spare parts

KEEP NO ENDS OPEN ON QUARTZ SLEEVES AND SENSOR WINDOW DURING STORAGE AND INSTALLATION!



There is a risk of condensation forming inside the quartz sleeves.

Make sure the electrical control cabinet is stored frost-free until time of installation.

All equipment must be stored in a non-condensing, non-corrosive place, until time of installation.

SAFETY INFORMATION

Always observe safety regulations applicable in your country to reduce the risk of fire, electric shock, and personal injury.

- The operator is liable for damage caused by installation and operating errors.
- The system may only be operated by trained and authorized personnel.
- The system may only be used in accordance with the technical data and specifications outlined in the operating instructions.
- The system is intended solely for the treatment of water; any other use or modification of the system is prohibited.

Confirm the Following

- Both reactor and cabinet must be connected to a grounded main outlet.
- The power supply for the UV system should be protected by HPFI.
- Make sure the equipment is properly supported and protected from vibrations.
- Do not install the UV system within an area subject to traffic.
- Before servicing, turn off the power supply to the UV system, eliminate hydraulic pressure by switching off pumps, closing relevant valves and finally opening the drain valve on the reactor. Otherwise, water pressure may force the quartz sleeves upwards during dismantling.
- Do not exceed specified rated water pressure.
- Water/fluid operating temperature do not exceed 140°F/60°C.
- The protection of the UV system from chemicals, dyes and vapor is guaranteed.
- Necessary precautions are taken in the event of flooding due to leakage.
- The UV lamps must be turned off if the water flow is stopped for more than one minute to avoid unintended overheating.
- The information in the operating instructions relating to the unit's service life must be observed.
- Call for service if needed.

CAREFULLY READ THIS MANUAL BEFORE INSTALLING THE UV SYSTEM.

KEEP THIS MANUAL IN A SAFE PLACE FOR FUTURE REFERENCE.

THE OPERATOR IS LIABLE FOR ANY DAMAGE CAUSED BY INSTALLATION OR OPERATING ERRORS

SAFETY INSTRUCTIONS

UV Reactor

MAKE SURE:

- Enough space for service work. Make sure it is possible to remove and re-install UV lamps and quartz sleeves.
- Provide valves upstream and downstream of the radiation chamber to shut off the reactor for maintenance work and consider installing extra drain valves upstream and downstream of the reactor to allow for water sampling.
- Always install the reactor chamber with UV-lamp(s) in a horizontal position.
- Only operate the UV lamps when completely fitted and installed in the reactor.
- No air bubbles accumulate in the closed reactor (ensure air-bleed if necessary).
- Place a UV-warning label on the outer surface of the reactor. Make sure it is visible from all angles.
- UV-resistant pipe material up and downstream of the reactor. If PVC is used, it is highly likely that over time the PVC will discolor and become brittle around the connection.
- Reactor chamber can be emptied for service work.
- Reactor and piping are properly supported.

Please Note:

The UV-lamp will fail to ignite if in direct contact with quartz sleeve. Please ensure centering discs are properly located at each end of the UV-lamp.

Control Cabinet

MAKE SURE:

- Electric installation is done by an authorized electrical engineer.
- Generally applicable guidelines and local installation regulations are followed.
- The electronic control cabinet should always be locked and only opened by qualified personnel.
- Each electronic control cabinet includes a 29-foot cable and is intended for wall mounting or installation on a suitable frame. To ensure cable safety, it should be positioned within a distance that allows the cable to be securely fixed and protected from any surrounding activity. Proper placement helps prevent potential damage or disruption to the cables.
- Installation location is dry and frost-free. Frost and condensed water may destroy electrical components.
- The electronic control cabinet is protected against exposure to direct sunlight and rain.
- Only carry out installation work on the UV system if it is disconnected from the main power supply.
- Do not dismantle the electronic control cabinet. Dismantling the cabinet or modifying the connections inside the cabinet may result in electric shock or burn and will void the warranty.
- Provide overcurrent protection on the supply voltage before the cabinet cuts power at the specified “fuse max current”.
- Ambient temperature do not exceed 122°F/50°C (Heat exchanger or AC is optional).
- Airflow is unhindered around the air inlet and exhaust
- The cabinet door can be fully opened.

Please Note:

If the cabinet is not equipped with a sealed cooling system, make sure to mark it as unfit for waterjet cleaning if this is a method used at the installation site.

Input Signals

Below illustration shows terminals for external communication and power supply. Please note that terminals may deviate due to local supply options.

UV-lamp operation (ON-ON terminals)

UV-lamps can be started and stopped externally if a connection is made to a potential free relay (e.g. another PLC-system or switch at remote location) In the cabinet two contacts are marked ON. Wires connecting to an external potential free relay must be mounted for remote control.

UV-lamps will ignite if:

- Remote control is selected in the setup menu and the two terminals in the cabinet are connected
- The lamps will turn off when this connection is disrupted.

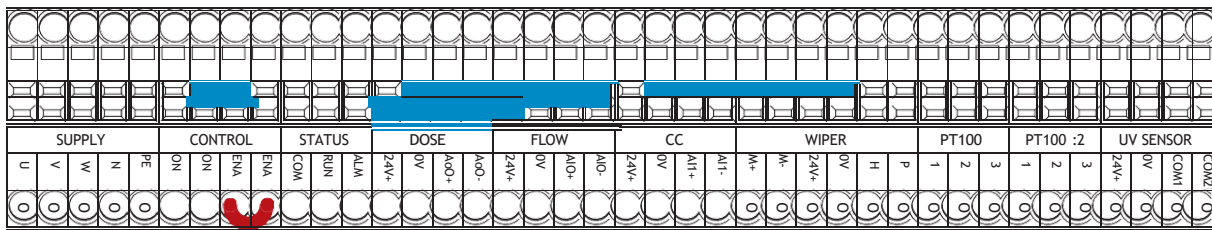

Installation Check List

ACTIONS		OK
[1]	Check all components for damage related to freight. Take pictures and contact Aquify immediately if damages are observed.	
[2]	The cable can reach the reactor vessel. (standard cable length is 29-feet)	
[3]	There is space for service operations on the reactor quartz sleeve and lamp.	
[4]	Both reactor and cabinet are properly grounded.	
[5]	Actions have been taken to avoid an accumulation of air in the reactor.	
[6]	UV-lamp will operate in a horizontal position when the reactor is installed.	
[7]	No connection between UV lamp glass and quartz sleeve.	
[8]	Fan ventilated cabinets must be installed in non-condensing environments. Corrosive aerosols will destroy electronics and void the warranty	
[9]	Airflow to and from cabinet fans is un-hindered.	
[10]	Connecting pipes have been properly supported.	
[11]	The power to the UV system will be disconnected if the flow is stopped.	
[12]	UV warning labels are clearly visible.	

GENERAL OVERVIEW

MAIN COMPONENTS

- [1] Reactor body
- [2] UV intensity sensor
- [3] Drain ports
- [4] Temperature sensor
- [5] Proximity sensor
- [6] Lamp connector
- [7] Visual inspection
- [8] Wiper system

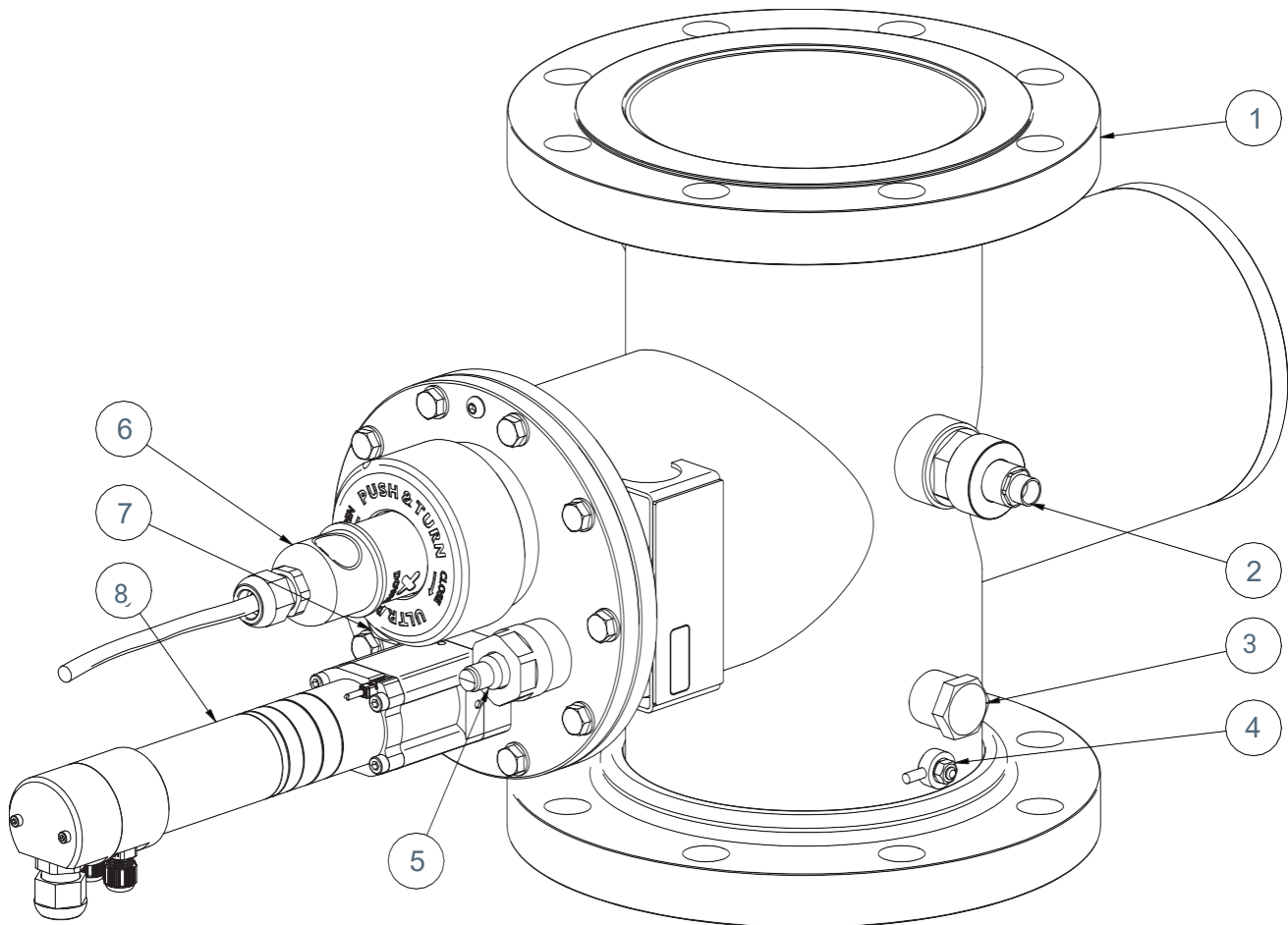

UV Selection and Design

Aquify recognizes the challenges that designers face to integrate products into their workflow in the age of automated design tools like Autodesk Revit. We provide 2D technical drawings, AutoCAD blocks for our 2D designers, and 3D files in multiple formats, including automated Revit families for our 3D designers.

Smart Part Numbering System Overview

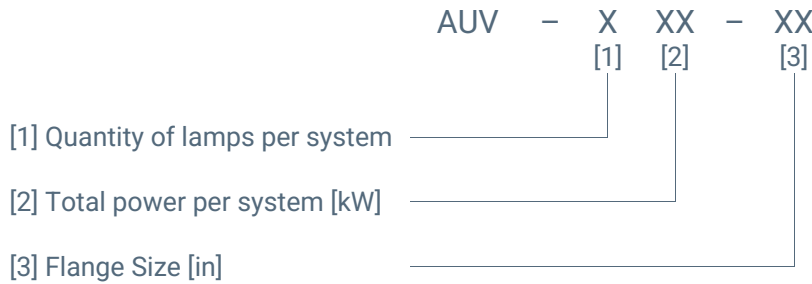

SIZING CHART						
Model	Flow Rate [gpm]		Flange Size [in/DN]	Lamps Qty	Power Per Lamp [kW]	Total Power [kW]
	Outdoor	Indoor				
AUV-106-03	125	115	3 / 80	1	0.6	0.6
AUV-206-04	350	300	4 / 100	2	0.6	1.2
AUV-125-06	645	610	6 / 150	1	2.5	2.5
AUV-225-08	1530	1490	8 / 200	2	2.5	5
AUV-240-10	2200	1650	10 / 250	2	4	8
AUV-340-12	3120	2700	12 / 300	3	4	12

Outdoor: sized at maximum flow rate capacity (gpm / LPM) @ 40 mJcm² UVT & 3log Crypto reduction

Indoor: sized at maximum flow rate capacity (gpm / LPM) @ 60 mJcm² UVT & 3log Crypto reduction

Max Design pressure: 145 psi (10 bar)

Flow Specification

PRODUCT FLOW INFORMATION TABLE						
Specification	AUV-106-03	AUV-206-04	AUV-125-06	AUV-225-08	AUV-240-10	AUV-340-12
Disinfection max. flow (94% UVT, 40 mJ/cm ²) [gpm]	125	350	645	1530	2200	3120
Disinfection max. flow (94% UVT, 40 mJ/cm ²) [m ³ /h]	28	79	146	347	500	709
Combined chlorine flow (94% UVT, 60 mJ/cm ²) [gpm]	113	300	610	1490	1650	2700
Combined chlorine flow (94% UVT, 60 mJ/cm ²) [m ³ /h]	26	68	139	338	375	613

PRESSURE DROP CLAIM								
Model	Flow Rate		Flow Rate [gpm], Pressure Drop [mbar]					
	[gpm]	[m ³ /h]	125	350	645	1530	2200	3120
AUV-106-03	125	28	12.4					
AUV-206-04	350	79	8.0	5.26				
AUV-125-06	645	146	0.5	3.8	12.5			
AUV-225-08	1530	347	0.3	1.9	5.9	31.1		
AUV-240-10	2200	500	0.1	0.6	1.9	10.0	20.4	
AUV-340-12	3120	709	0.1	0.6	1.7	8.1	16.2	31.7

DISINFECTION EFFICACY

These models have demonstrated the ability to provide 3-log inactivation of *Pseudomonas aeruginosa* and *Enterococcus faecium*. The products are designed for supplementary disinfection and are intended for use with appropriate residual levels of EPA registered disinfecting chemicals. Specific residual levels of EPA registered disinfecting chemicals may be required by the regulatory agency having authority.

Pseudomonas aeruginosa and *Enterococcus faecium* were used for testing and were not correlated to *C. parvum*. The UV dose delivered is sufficient to provide a 3-log inactivation of those organisms at the flow rates in the flow specification table of the manual at UV intensities achieved with UVT values of 94% or higher.

DECLARATION:

This unit has been tested to confirm a minimum inactivation equivalent of 3 log (99.9%) *C. parvum* in accordance with NSF/ANSI/CAN 50 and the U.S. EPA UV DGM. This product has met the requirements of NSF/ANSI/CAN 50, Section N-8.1: Disinfection Efficacy, for a ≥ minimum of a 3-log (99.9%) reduction of *Enterococcus faecium* [ATCC #6569] and *Pseudomonas aeruginosa* [ATCC #27313]. This product is intended for secondary disinfection and is intended for use with appropriate residual levels of U.S. EPA-registered disinfecting chemicals. Specific residual levels of U.S. EPA-registered disinfecting chemicals may be required by the regulatory agency having authority.

This unit has demonstrated an ability to provide 3-log inactivation of *Pseudomonas aeruginosa* and *Enterococcus faecium*. This product is designed for supplementary disinfection and is intended for use with appropriate residual levels of U.S. EPA registered disinfecting chemicals. Specific residual levels of U.S. EPA registered disinfecting chemicals may be required by the regulatory agency having authority.

FOR DETAILS, PLEASE REFER TO VALIDATION SPECIFICATION (ANNEX OF THIS DOCUMENT)

Technical Specification

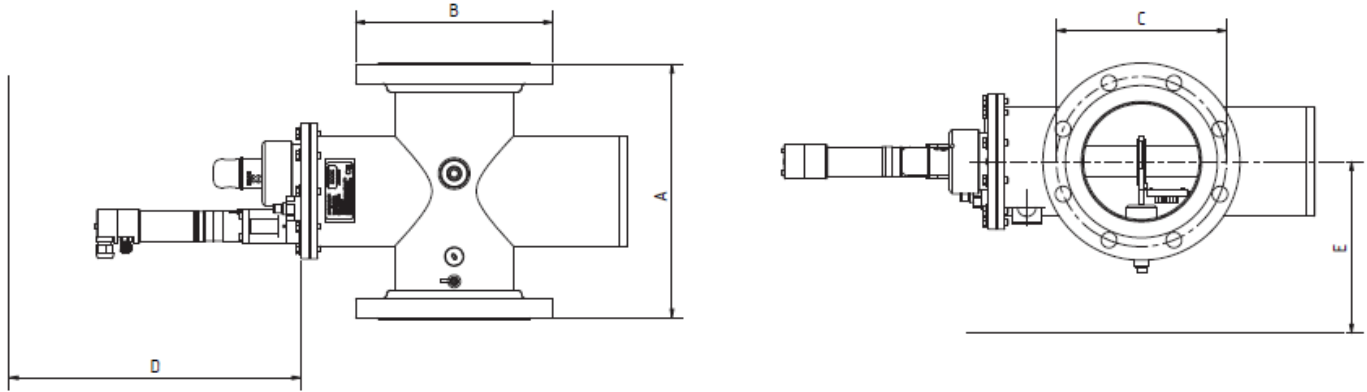

UV TECHNICAL SPECIFICATION TABLE

Specification	AUV-106-03	AUV-206-04	AUV-125-06	AUV-225-08	AUV-240-10	AUV-340-12
Connection Size	ANSI 3in /DN80	ANSI 4in /DN100	ANSI 6in /DN150	ANSI 8in /DN200	ANSI 10in /DN250	ANSI 12in /DN300
Connection Type	ANSI Class 150 / DN PN 10					
Design Pressure	145 PSI / 10 Bar					
Chamber Material	SS316L					
Configuration	In-line					
Surface Finish	Electropolished Internal and External					
Ingress Protection	NEMA4 / IP65					
Minor Wetted Parts	PTFE, PVDF, VITON					
Lamp Type [W]	1 x 600	2 x 600	1 x 2500	2 x 2500	2 x 4000	3 x 4000
Quartz Type	High purity fused quartz					

DIMENSIONS						
Weight Dry [lb/kg]	41 / 19	57 / 26	68 / 31	101 / 46	117 / 53	179 / 81
Weight Filled [lb/kg]	53 / 24	77 / 35	93 / 42	154 / 70	192 / 87	295 / 134
A [in/mm]	12.6 / 320	13.4 / 340	14.2 / 360	15.7 / 400	16.5 / 420	18.9 / 480
B [in/mm]	7.5 / 190	9.0 / 230	11.0 / 280	13.6 / 340	15.9 / 400	19.0 / 485
C [in/mm]	6.0 / 155	7.5 / 190	9.5 / 245	11.8 / 300	14.3 / 365	17.0 / 430
D [in/mm]	13.8 / 350	19.7 / 500	19.7 / 500	19.7 / 500	24.8 / 630	24.8 / 630
E [in/mm]	8.1 / 206	8.6 / 219	8.3 / 211	8.7 / 221	10.7 / 272	11.5 / 292

The above dimensions reference the following:

- D – The space required to service the lamps and quartz
- E – The space required to service the UV Sensor

Installation of UV Reactor

Please also refer to model specific installation drawing.

Always check if reactor has a specific flow-direction. This will be marked with a sticker on the reactor.

****NOTE:**** LAMPS MUST BE HORIZONTAL AT ALL TIMES

LAMP

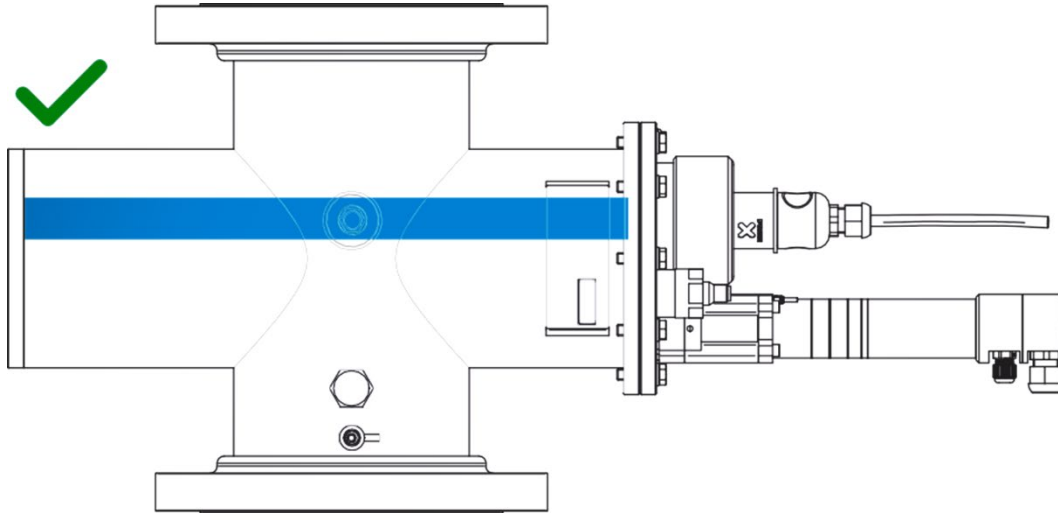

Installing the reactor incorrectly will place the lamp vertically.

This will result in failure of the lamp and overheating of the system causing damage.

Lamp Alignment

IMPORTANT!

The washer for the quartz sleeve must at all times and in all installations be positioned with the lamp alignment groove pointing upwards on the reactor!

The washer (2) for quartz sleeve (1) can be rotated after unscrewing the bolts (5).

Be careful both the gasket (4) and the quartz o-ring (3) is in place when screwing the bolts back into the reactor.

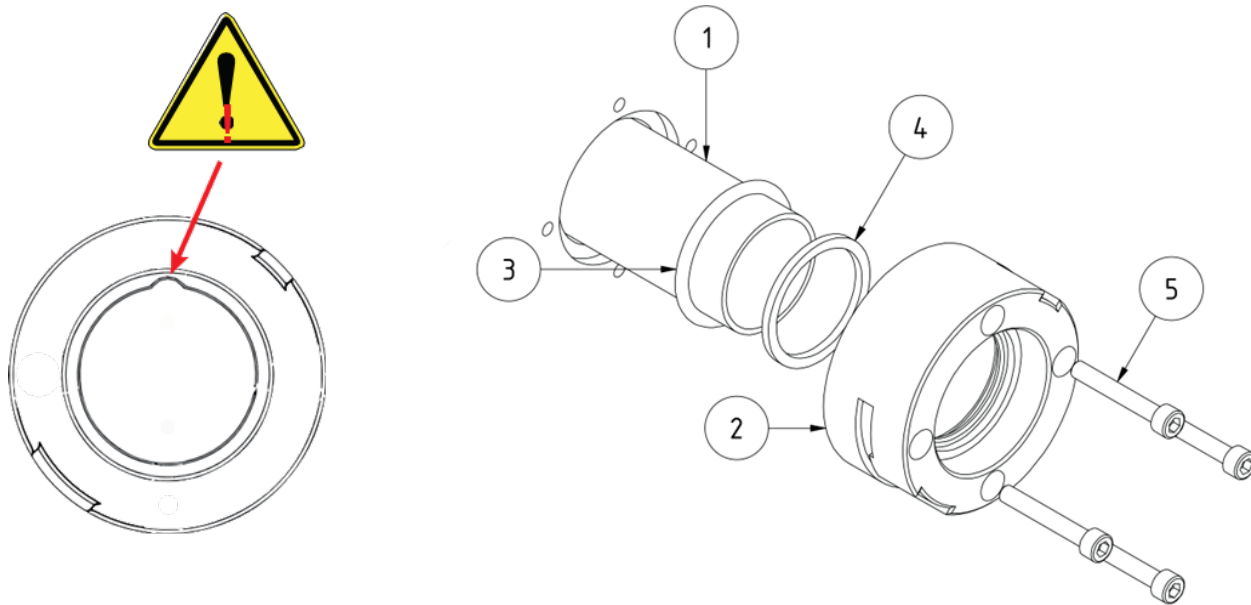

Safe Distance to Non-UV Resistant Materials

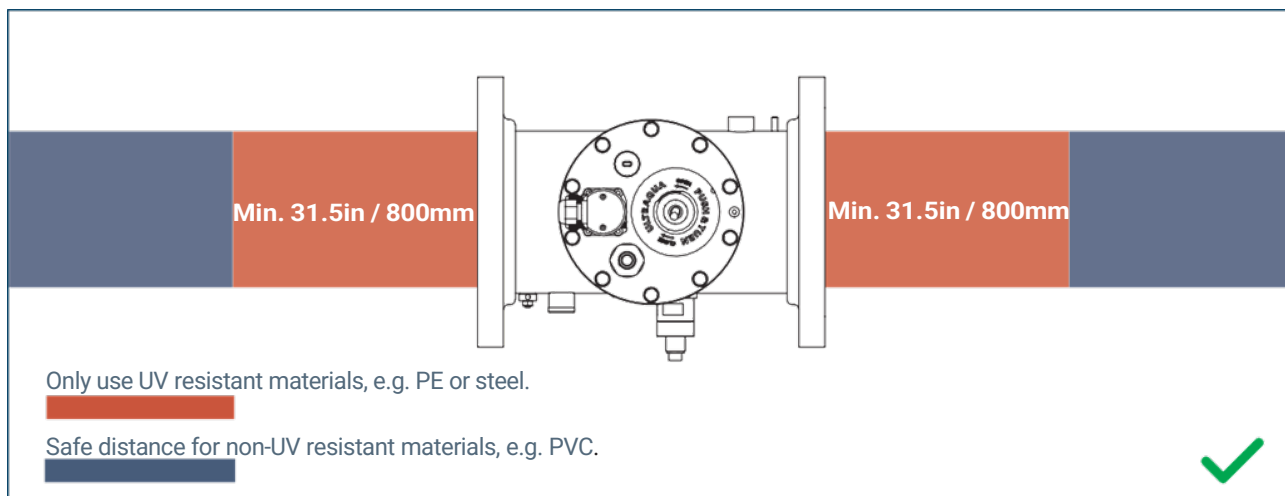

CONTROL CABINET

MAIN COMPONENTS

- [1] Mounting brackets
- [2] Enclosure Lock
- [3] Power switch
- [4] Fan
- [5] HMI
- [6] Cable glands

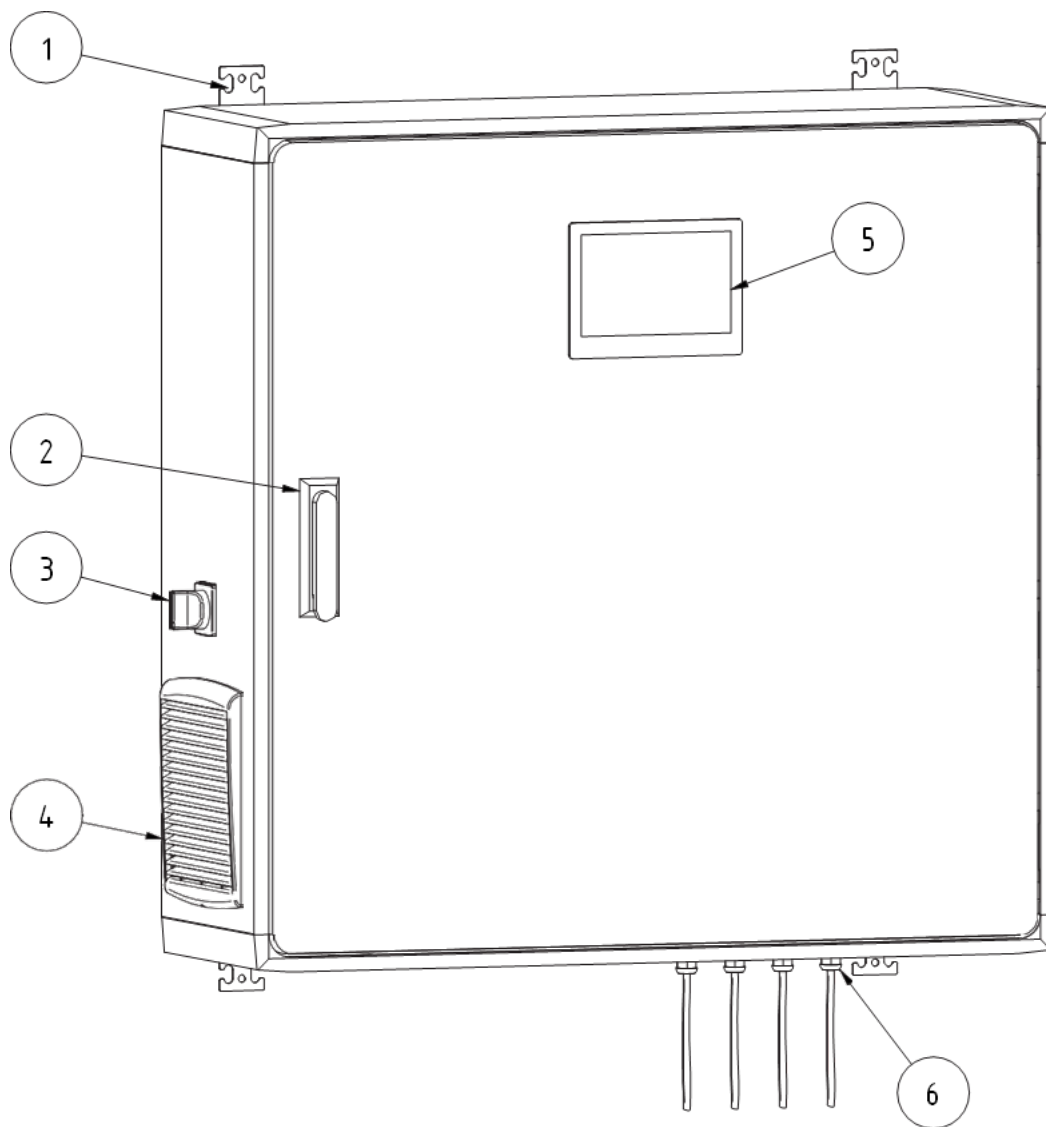

Technical Specifications

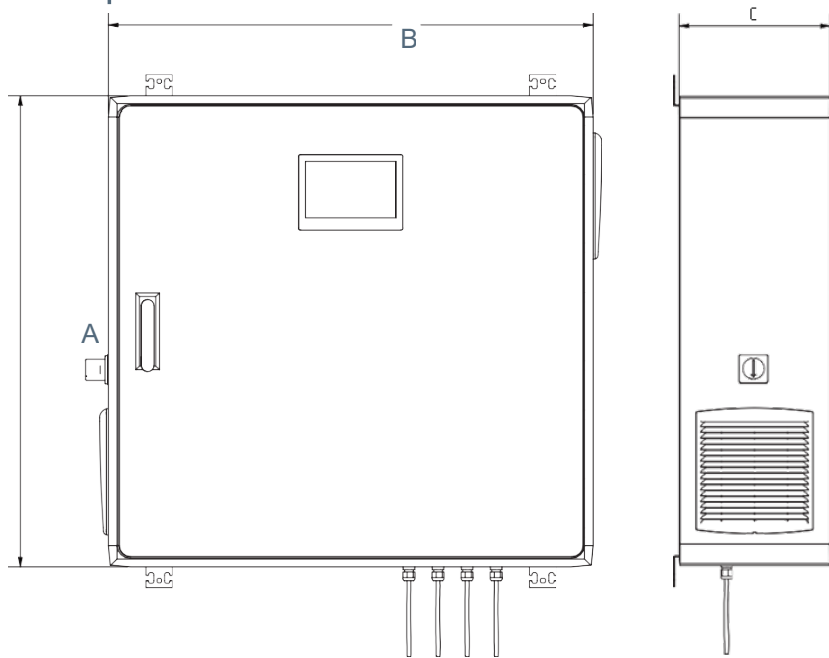

CABINET TECHNICAL SPECIFICATION TABLE

Specification	AUV-106-03	AUV-206-04	AUV-125-06	AUV-225-08	AUV-240-10	AUV-340-12
Ballast Type	Electrical					
Control Logic	PLC					
Ingress Protection	NEMA13/IP54					
Installation	Wall mount 0-45 ° non-condensing					
Lamp Drivers	1	2	1	2	2	3
Power Consumption [AMP]	3 A	6 A	14 A	28 A	12 A	12 A
Power Supply	1x208/ 230VAC +/- 10% L2/(N) +GND 50/60Hz				3x400/480 VAC +/- 10% L2/(N) +GND 50/60Hz	
Cable Length [ft]	29					
SCADA Communications	MODBUS TCP/IP					
Thermal Control	Fan					
Material	Powder Coated Steel					

DIMENSIONS

Weight [lb/kg]	110 / 50	165 / 75	165 / 75
A [in/mm]	27.5 / 700	31.4 / 797.6	39.3 / 999
B [in/mm]	19.6 / 498	31.4 / 797.6	31.4 / 797.6
C [in/mm]	10.2 / 259	11.8 / 300	11.8 / 300

UV CHAMBER Reactor Body

The reactor is made of SS316L. The complete body and endplate have been passivated and electropolished to withstand corrosion. However, higher grade steel material may be needed in aggressive environments or when:

- Chloride concentration > 1%
- Chlorine concentration > 3 mg/l
- The reactor or any other part of the treatment system is not properly grounded
- Ferrous particles settle in the reactor

In order to avoid corrosion on the reactor's external surfaces it is recommended once yearly to wash it with fresh water and with paraffinic oil. This should always be done after a leakage incident.

UV Lamps

The UV-lamp is of medium pressure type. It has a high-power density which results in an operating temperature of 1562°F/850°C.

It is important that the UV lamp cools down before re-ignition. The cool-down period is controlled by the PLC (IGNITION CYCLE DELAY) and the default value is 300s. If water temperature is < 50°F/10°C, the delay time can be reduced to 200s. Lamp ignition problems and shorter lamp lifetime may be a result of too short switching cycle delay. In the same way it is also optimal for the UV lamps if they are allowed to heat up completely before being switched off.

Handling of the UV-lamps should be done very carefully. Gloves are recommended as fingerprints will burn onto the lamp and reduce performance.

Lifetime of the UV-lamp is 9,000 operating hours. After 9,000 hours emission intensity has fallen below the levels used in reactor design and UV-dose calculation. This means that efficient performance of the UV-reactor can no longer be expected. Remember to reset the hour counter in the "OPERATION HOURS" menu after lamp replacement.

When cleaning (lamps) with alcohol, always remove the residue with a dry cloth.

The UV-lamp is designed to perform optimally at full power. Dimming the lamp will save power, but efficiency (UVC- output/Input power ratio) will fall when lamps are dimmed more than 40%. Constant operation in this state may also reduce lamp lifetime.

Please note that medium pressure lamps contain liquid mercury , which requires careful handling in case of breakage. UV lamps and any spilled mercury must be thoroughly cleaned up and disposed of in accordance with local regulations. These lamps are typically discarded alongside standard fluorescent light tubes, ensuring safe and environmentally responsible waste management.

Replacement of UV-Lamps

Switch off UV-lamps and subsequently switch off power using the main breaker. It is also recommended to depressurize the reactor during lamp service

The AUV Series is fitted with a custom lamp connector, which ensures lamp replacements can be carried out without the use of any tools.

IMPORTANT!

Wear thin protective gloves suitable for fine mechanical work with glass!

IMPORTANT!

Wear protective goggles! (Risk of high-pressure water spray, UV light, and fragmented quartz glass)

IMPORTANT!

Exercise caution when handling the UV lamp immediately after shutdown, as it will remain very hot for the first few minutes. Operational temperature is >1562°F/850°C.



Removing UV Lamp

For removing the UV-lamp, push and turn the cap (1)(2) to unlock the lamp connector (3). Pull the lamp connector out with the UV-lamp mounted, until the steel rods are exposed (4). Hold on to the steel rods of the UV-lamp (5) and disconnect the lamp connector (6). Finally pull out the UV-lamp for service or re-placement.

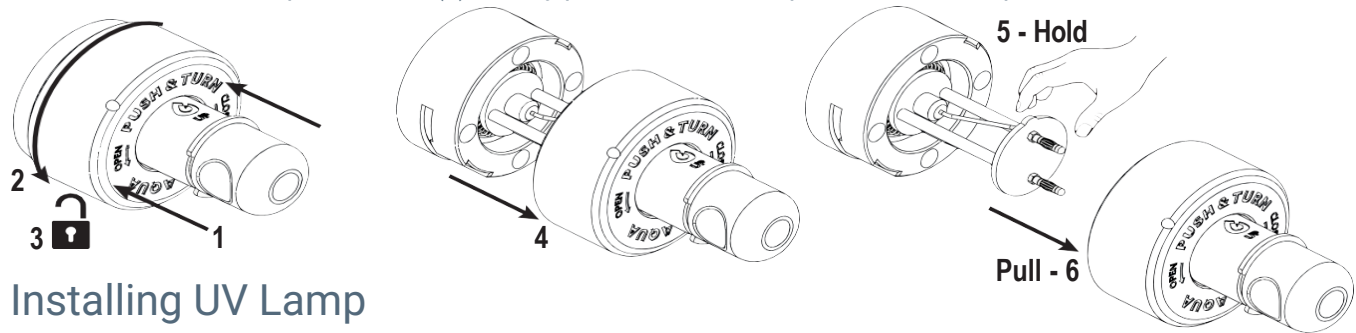

Installing UV Lamp

To install the lamp, push it into the quartz sleeve (1) and ensure the upper half circle of the lamp connector disk is aligned inside the quartz washer (2). Before mounting and installing the lamp connector, ensure that the logo and UP text is oriented in the upwards position (3). It is not possible to lock the lamp connector cap if the cross is facing in the upwards direction - arrange the lamp connector accordingly and push it into position (4). Push and turn the cap (5) and (6) to lock the lamp connector in position (7).

IMPORTANT!

Confirm the circular springs located on the UV-lamp ends are installed correctly and they are in a good condition.

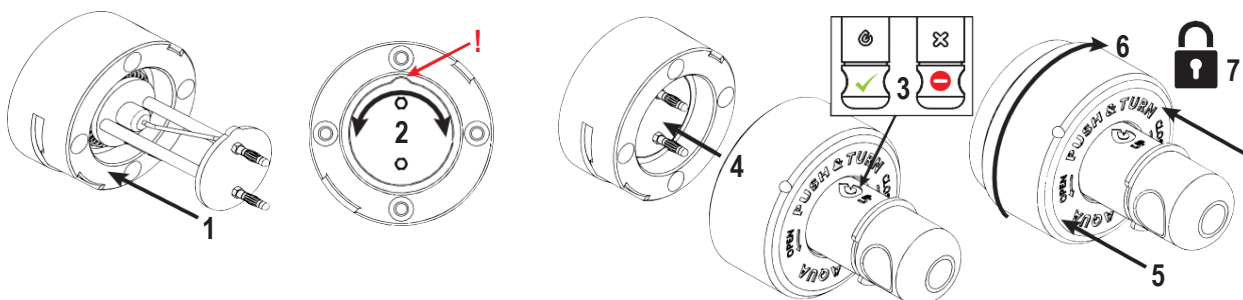

Removing Broken Lamps and Quartz Broken Lamp/Quartz Sleeve in Air

- For broken lamps e.g., by hitting the ground, remove all personnel from the room.
- Allow the room to ventilate for 15 minutes, before the room is clear to re-enter.
- Wear gloves and long sleeves when removing the shards.
- Wash all clothing which has been exposed.
- For quartz sleeves remove the glass shards as normal glass waist.



Broken Lamp/Quartz Sleeve in Water

Wear protective gloves when moving the shards, and check filters both up and downstream. Typically, it is necessary to dismantle the system to remove all shards.



WARNING: WEAR PROTECTIVE GEAR WHEN HANDLING CONTAMINATED GLASS
THE LAMP CONTAINS MERCURY AND WILL IN CONTACT WITH AIR VAPORIZE AND BE HAZARDOUS TO INHALE.
USE GAS RESPIRATOR, GOGGLES, GLOVES ABLE TO HANDLE MERCURY.

IN CONTACT WITH WATER, IT WILL BIND TO THE WATER MOLECULES AND BE LESS LIKELY TO VAPORIZE.

Quartz Sleeves

Quartz sleeves are made of high purity quartz material optimized for low absorption of UVC rays in the 200-400 nm range. Due to material solarization, lifetime is limited to approximately 25,000 operating hours. Quartz sleeves will heat up during operation. This may result in mineral deposition on outer surface. Frequent cleaning (wiper cycles) may be necessary.

Natural waters containing dissolved organic matter or water containing high concentrations of dissolved minerals such as cooling water will require very frequent cleaning cycles and sometimes manual cleaning using acids.



When using alcohol-based cleaners on the lamp, allow additional time for thorough drying. Ensure complete evaporation of the cleaner before reigniting the lamp to prevent any risk of damage to the lamp.

IMPORTANT!

Always depressurize reactor before commencing service work on quartz sleeves. There is a risk of serious injuries. Quartz sleeves or pieces of the broken quartz sleeve can be blown out of the reactor.



IMPORTANT!

Always use cut-protection gloves when handling quartz sleeves.

IMPORTANT!

Note that the quartz sleeve must pass through a wiper ring inside the reactor.

DO NOT remove all quartz sleeves of the system at the same time, as this could rotate the internal wiper plate unintentionally, thus making the installation of new quartz sleeves challenging.

REPLACEMENT OF QUARTZ SLEEVES

Before replacing quartz sleeves (1) it is strongly recommended also to replace wiper rings.

Open drain valve and remove UV-lamp and lamp connector. Next, remove quartz washer endcap (2) and bolts (5). Pull out quartz sleeve, discard O-ring (3) and control the condition of quartz washer endcap (2) internal flat gasket (4), replace if required. Insert new sleeve (1) and insert new greased O-ring (3). Use a very small amount of silicon grease.

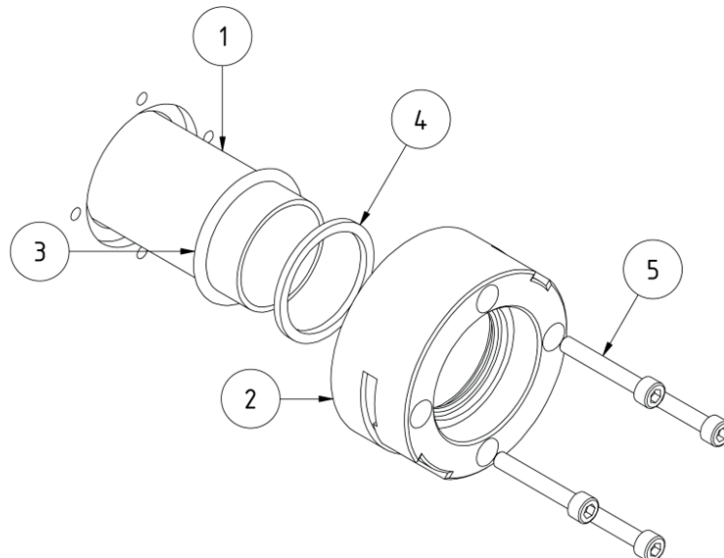

Wiper System

As the UV system is operating, fouling on quartz sleeves is inevitable. In order to ensure that the efficiency of the system is maintained, frequent wiper cycles is required.

AUTOMATIC QUARTZ SLEEVE CLEANING SYSTEM

UV systems in the AUV series are fitted with an automatic CZ42 wiping system.

The motor is programmed from the factory to have a maximum torque during calibration and operation. The maximum resistance is tested and defined at the workshop. If the motor gives a “spindle length fault” at initial start-up, drain the unit and check that no foreign objects are inside the reactor chamber and check that the claw couplings are firmly tightened to the motor and the spindle. If the motor gives a spindle length fault during operation and there are no obvious explanations, it is recommended to contact an authorized Aquify service provider.

REPLACEMENT OF CZ42 CLEANING WIPER

The CZ42 wiper motor (3) is connected to the spindle seal housing (5). Initially, when installing the wiper motor, notice the keyway on the spindle and position the jaw coupling (1) accordingly. Next, insert the jaw coupling spider (2) into the jaw coupling (1), before mounting the wiper motor (3) by use of the four bolts fasteners (4).

IMPORTANT!

The motor should NEVER be cleaned using water jets or corrosive cleaning agents!

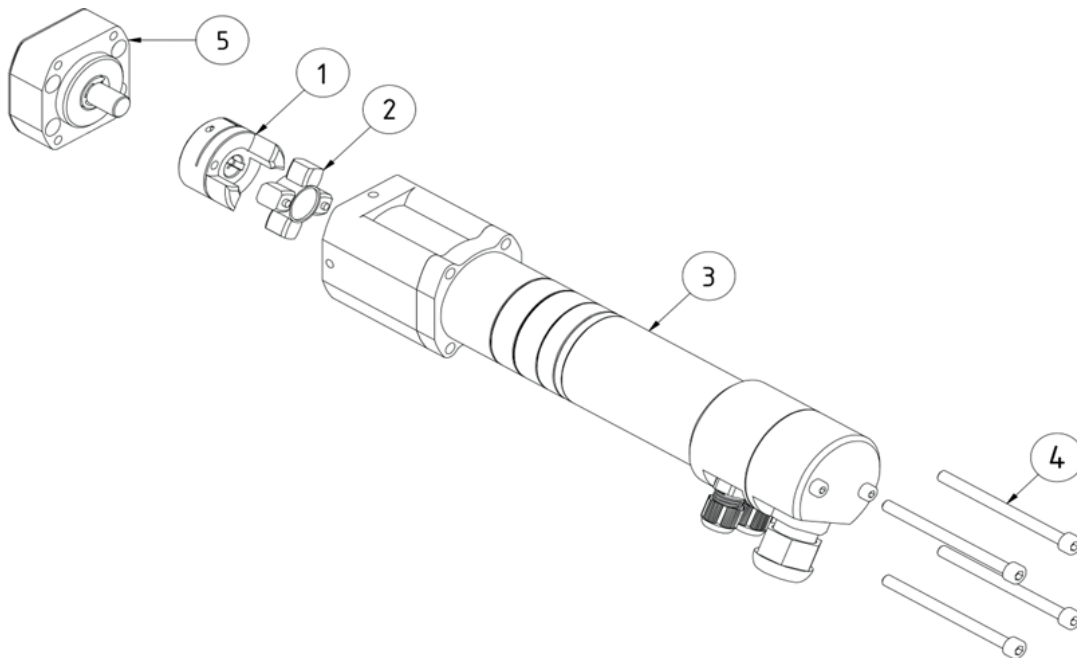

Replacement of Spindle Seal

The spindle sealing is mounted inside the seal house which is mounted on the endplate. All to ensure a tight seal around the spindle.

Take care not to scratch the seal, spindle seal area and the seal housing.

It is advised to replace the seal with a new one when the unit is re-assembled. Remember to grease well when re-mounting.

Initially remove the wiper system and detach the jaw coupling (7) Check if spindle key (8) is still in place, if loose it should be removed and stored during disassembly. Remove the seal housing (5) by removing the four screws (6) and pulling off the housing. Remove outer spindle clip (4) and remove the spindle bearing (3). Next, push the special sealing (2) forward, for easy removal of the remaining inner spindle clip (4). Finally, pull the special sealing (2) off the spindle (1).

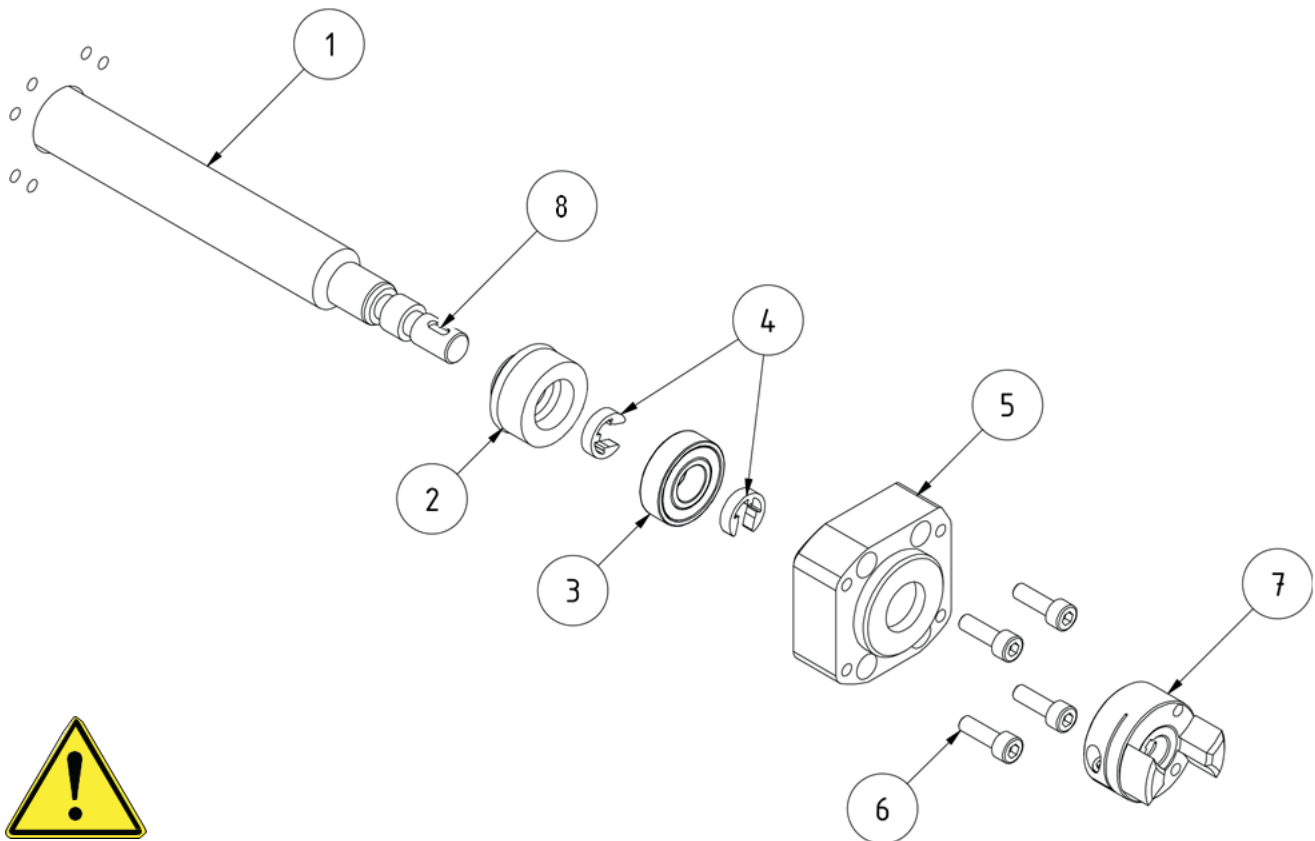

IMPORTANT!

Always replace wiper spindle seal (2) after 5,000 cycles or in one year, whichever comes first.

Replacement of Wiper Ringer

When replacing quartz sleeves, it is also recommended to replace the wiper ring.

First remove quartz sleeve and spindle seal. Next, remove the endplate (2) by unfastening its bolts (1), this exposes the endplate O-ring (3). Remove the spindle (4) and wiper plate (6) from the spindle bearing on the bottom plate. As quartz sleeves are removed, the wiper ring (5) is untied and loosened from the wiper plate (6) and is easily replaced manually. Visually inspect the brush (7) and the thread of the wiper spindle nut (8), to adjust and/or replace if needed.

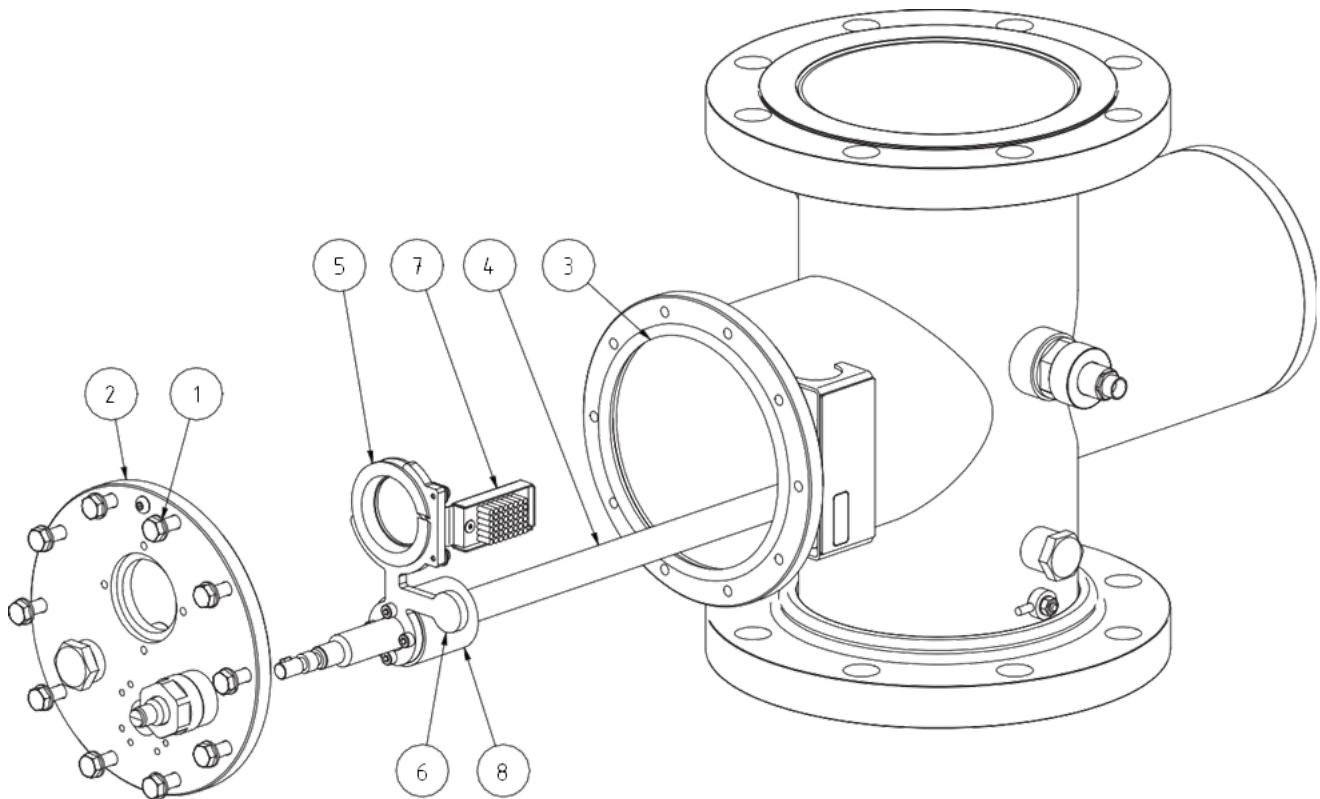

IMPORTANT!

Removing all quartz sleeves at the same time releases the rotation of the wiper plate. This can unintentionally rotate its direction and make the installation of new quartz sleeves more challenging.

IMPORTANT!

Rotating the wiper plate can cause the UV sensor brush (7) to be unaligned with the location of the UV sensor. If so, care should be taken to ensure the correct orientation of the wiper plate (6) and UV sensor brush (7).



Bottom Plate

On the bottom plate (1) a spindle bearing (2) and numerous rear holders for the quartz sleeves (3) are installed.

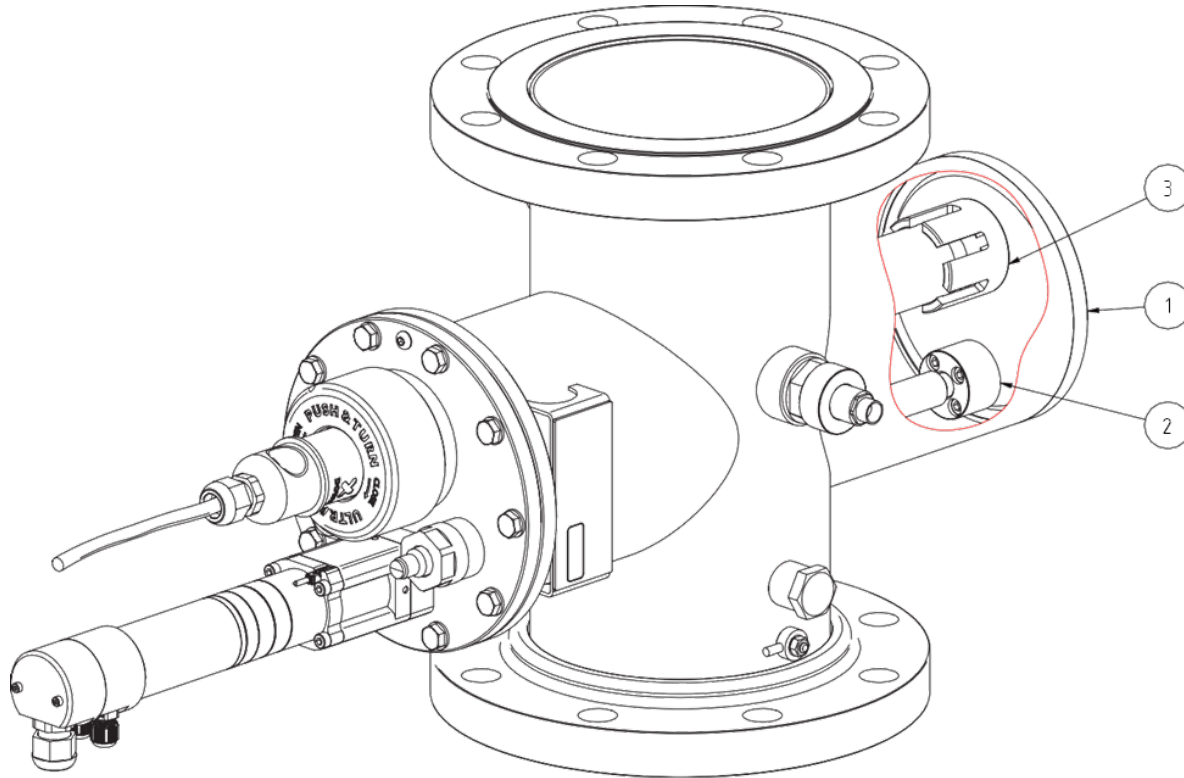

Temperature Sensor and Switch

There is one temperature sensor (PT100) mounted on the bottom side of the reactor body (4) and a second temperature sensor (PT100) mounted on the top of the opposite side of the reactor body. To avoid heat damage, the UV-lamps will automatically switch off, at a set temperature alarm level. The factory default setting is 122°F/50°C and pre-alarm level is 113°F/45°C.

It is advisable to set the temperature limits as low as possible to reduce the risk of fouling

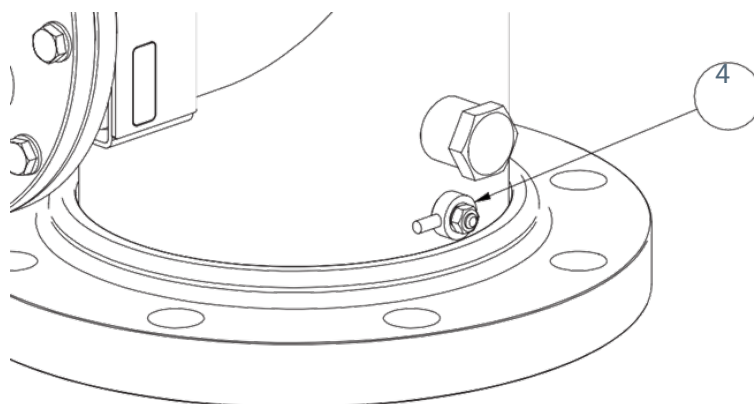

UV Sensor

If the UV sensor is removed from the sensor window, high-intensity, harmful UV radiation will be emitted from the sensor window. There is a risk of irreversible serious damage to the skin and eyes. Designated protective gear must be worn when checking and recalibrating the UV sensor (goggles and gloves etc.)



Uninstalling/Installing UV Sensor

For removing the UV sensor (3), the cap mounted on sensor (4) is loosened and the sensor can be pulled out. To replace sensor window the UV chamber needs to be depressurized. Unscrew housing (2) lubricate O-ring (1) and install new housing (2).

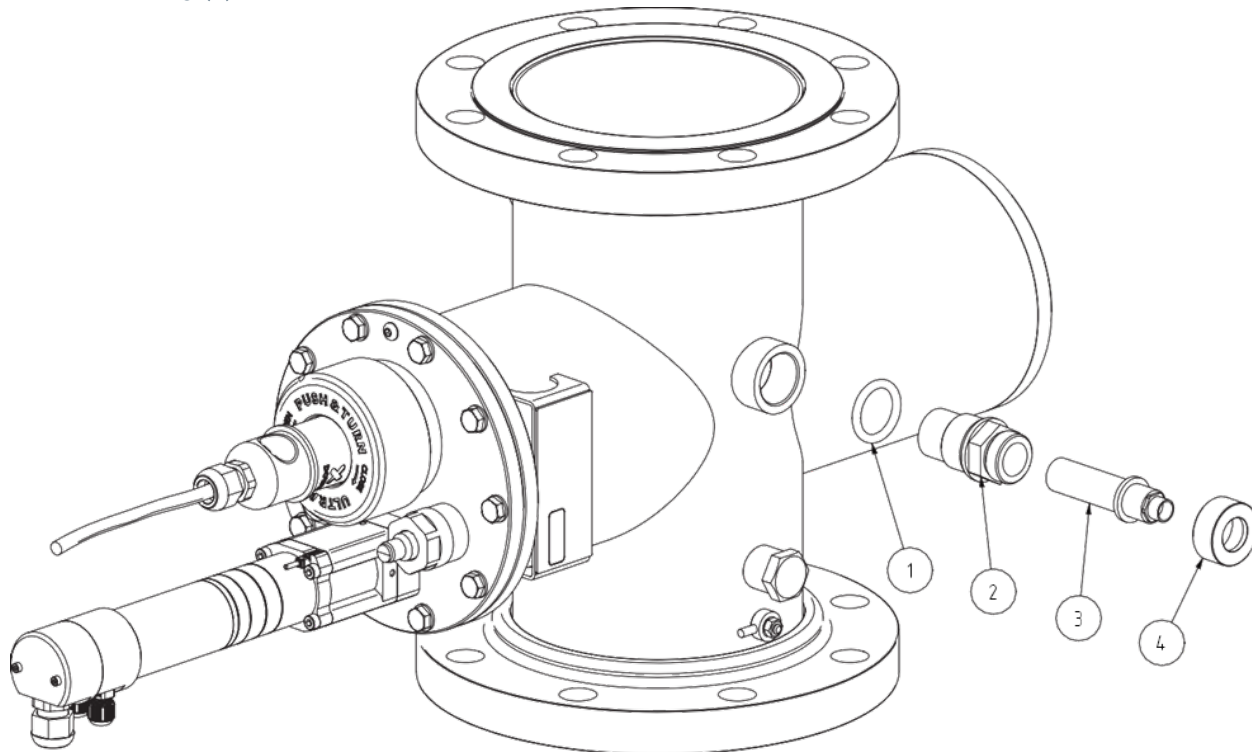

Winterization

- Empty reactor of water.
- Flush with tap water to remove any residual chlorine.
- Remove quartz sleeves and lamps.
- Store control cabinet in a dry place.

****NOTE:**** The sensor should be replaced every 12 months. Please contact Aquify for additional details.

Sacrificial Anode

The UV is equipped with sacrificial anode to protect chamber and parts from corrosion. The anode (33) will be consumed in doing so and therefore require replacement for the protection to be maintained.

The lifetime of the anode depends on the water quality in general.

Connect the anode to the grounding screw (11).

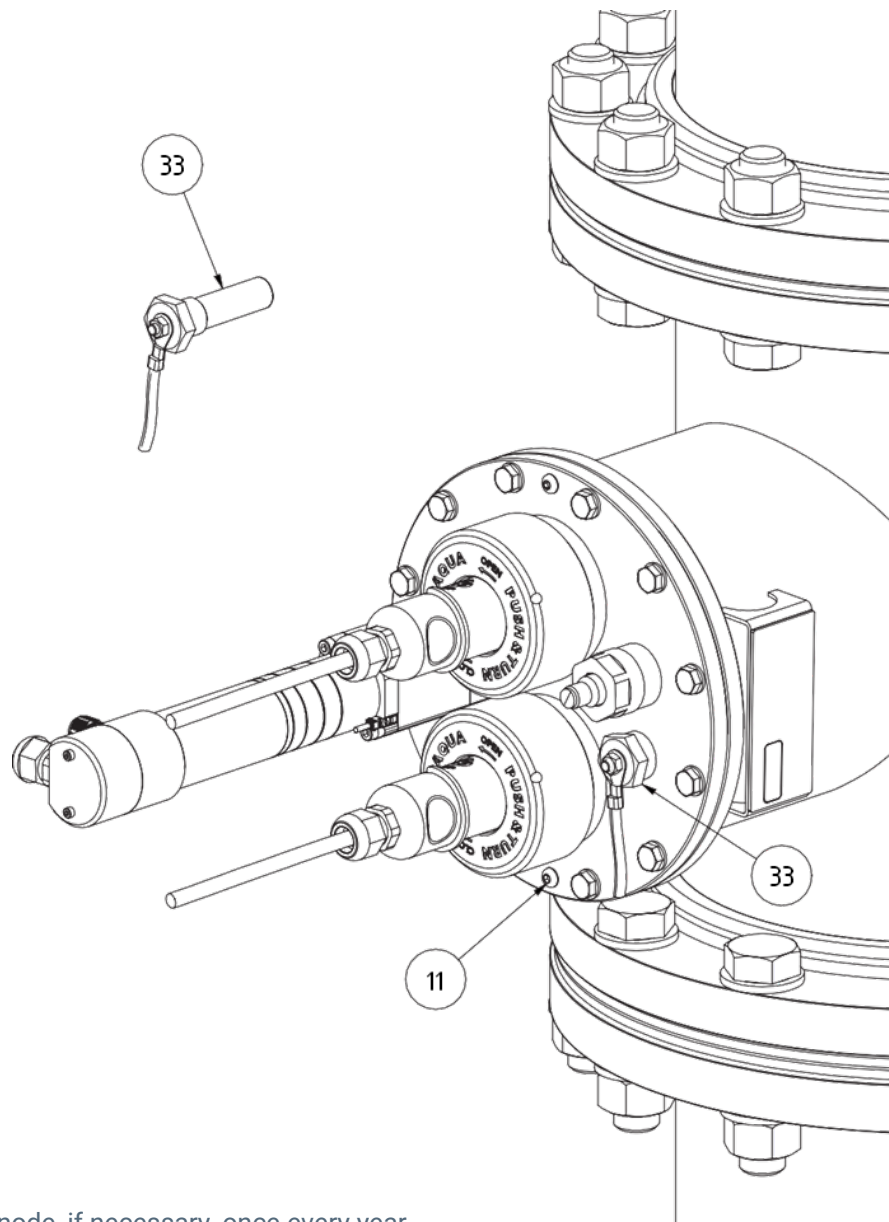

IMPORTANT!

Check and replace anode, if necessary, once every year.

Witches Hat Strainer

The Aquify's Witches Hat Strainer acts as an additional protective measure in the UV reactor system and is essential for swimmers' safety. In the event of a failure in the UV lamp or quartz sleeve, the strainer prevents debris from flowing downstream. They are specifically designed to be installed in a removable in-line spool directly after the UV reactor. For ease of maintenance, it's recommended that they be positioned in an accessible, unobstructed area, allowing for cleaning and inspection.

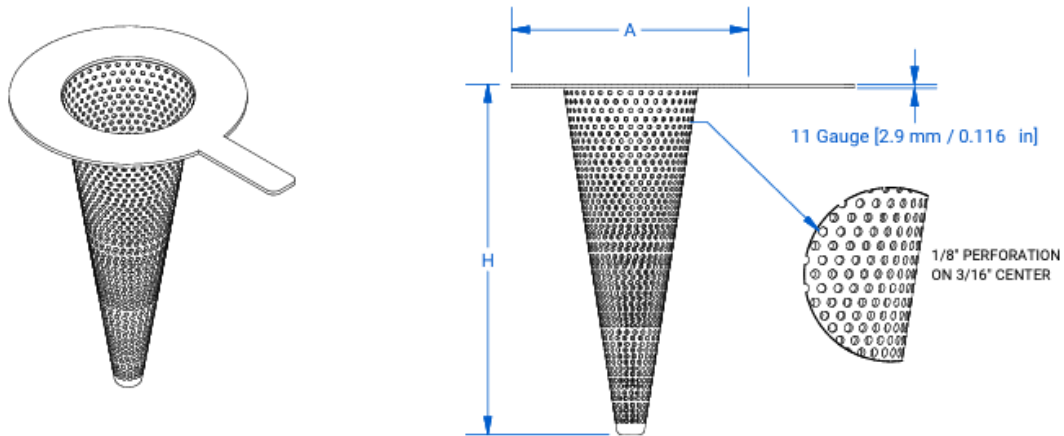

DESCRIPTION				
Model	Pipe Size NPS [in]	øA OD [in]	øA ID [in]	H Cone Height [in]
AUV-106-03	3	5.25	2.75	7
AUV-206-04	4	6.75	3.75	10
AUV-125-06	6	8.63	5.38	13
AUV-225-08	8	10.88	7.38	17
AUV-240-10	10	13.25	9.38	21
AUV-340-12	12	16	11	25

Always mount strainer in the flow direction and after the UV with matching gaskets (101). It is also highly advisable to mount the filter with possible access for service.

Service and cleaning of the filter is recommended.

Be aware that mounting the strainer will increase head loss significantly.

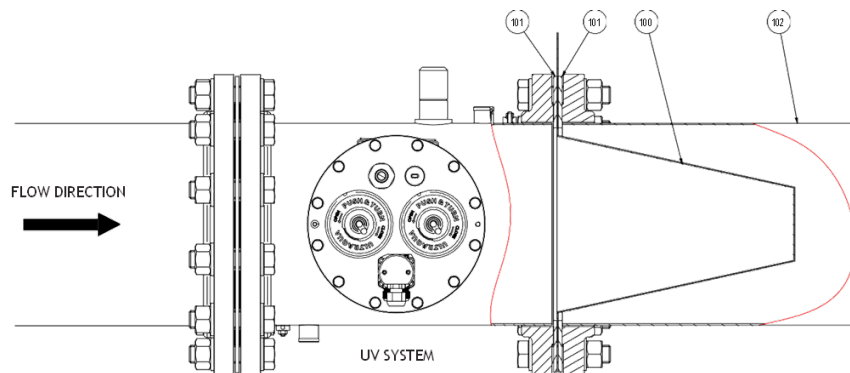

OPERATIONAL CONTROL

Control Start-Up

Before connecting to power please check the following:

- UV lamp has been plugged in.
- Temperature sensor is connected and in place.
- Protective grounding cables has been mounted on both cabinet and reactor.
- Quartz sleeve is dry inside before start-up. Condensation may develop inside the sleeve or sensor port when the UV lamp has been turned off for an extended period.
- UV sensor is connected.
- Reactor is not leaking.

Start-Up Wizard

When the system is powered ON it will show the Startup Wizard. This is designed to help the operator set some basic parameters from the beginning.

This includes:

- Language
- Time
- Home screen view

****NOTE:**** It is always possible to enter the Start-Up Wizard again at a later date if necessary.

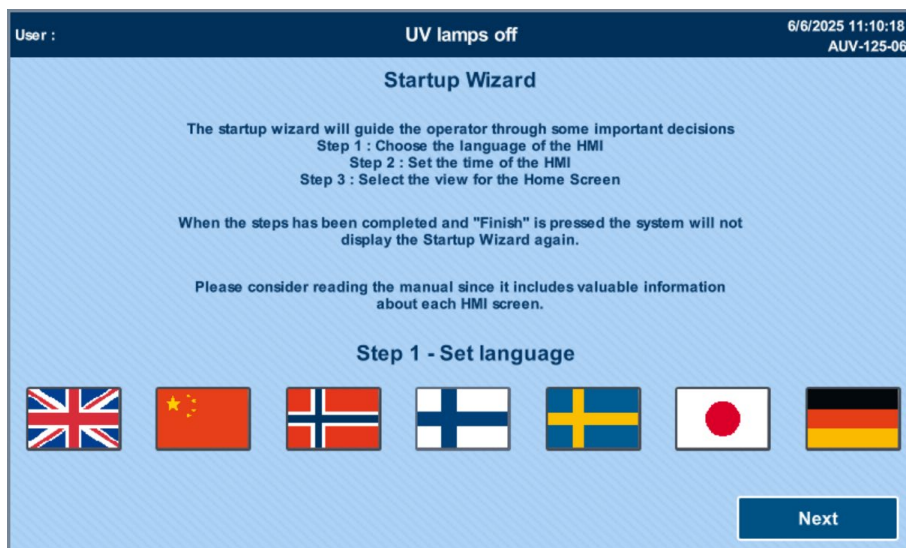

Step 1 – Set Language

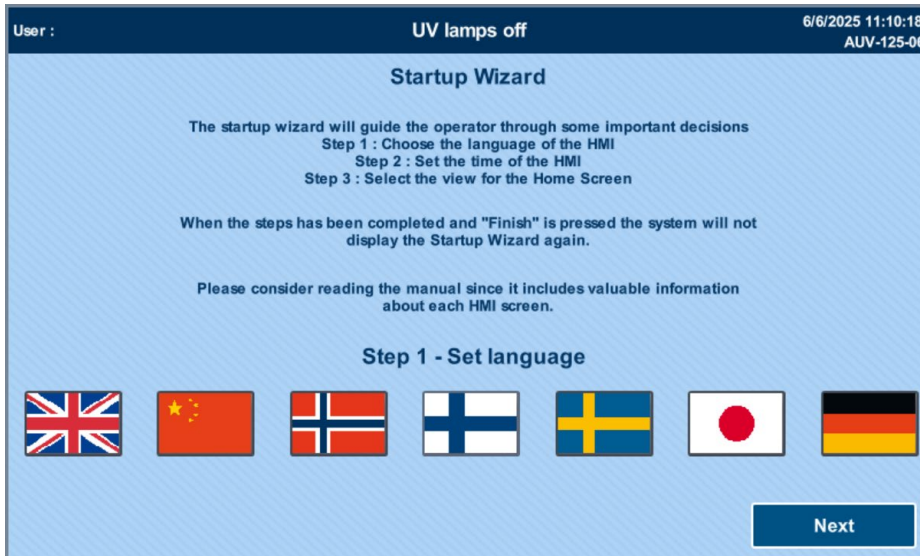

There are multiple languages to choose from:

- English
- Chinese
- Norwegian
- Finnish
- Swedish
- Japanese

When chosen it will be the language of all the HMI texts.

Step 2 – Set System Time

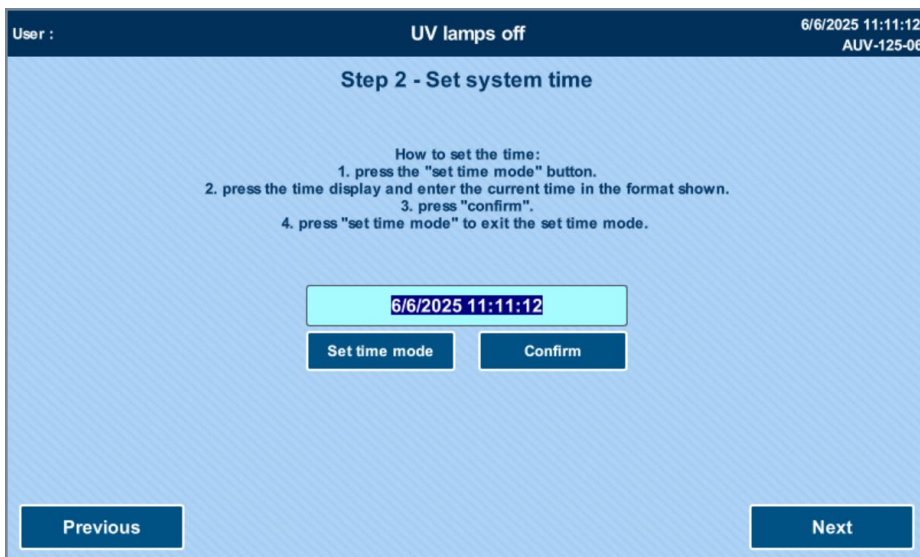

Here the operator must set the UV system time according to the local time zone. It is important to set the time in the same format as is shown in the display.

On the HMI there is a small description to help set the correct time.

Step 3 – Home Screen View

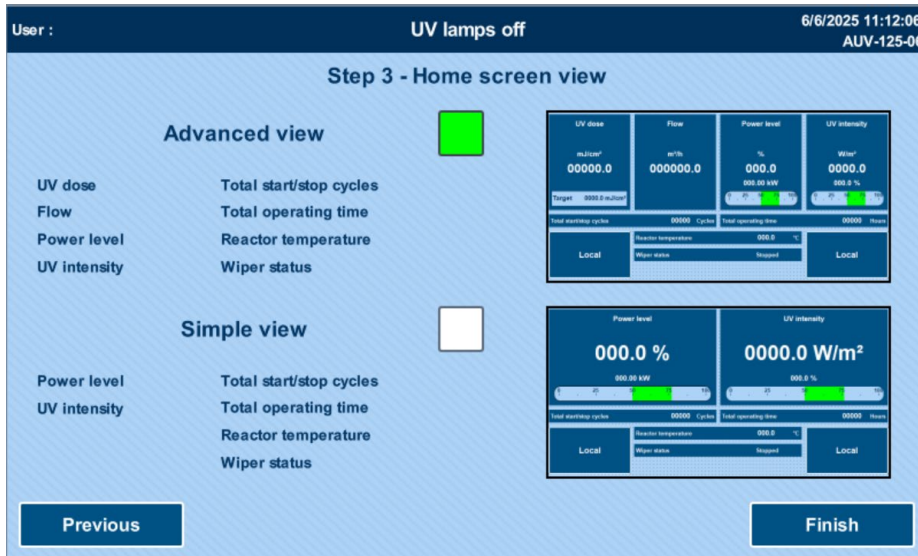

As default, the system will show the advanced view.

This will display the most information from the system and is recommended in almost all situations.

If the operator wants to keep it simple and does not require UV Dose or flow, then a simpler view can be chosen.

This will only display Power level and UV intensity as the main parameters.

Advanced view will display:

- UV Dose
- Flow
- Power level
- UV Intensity
- Total start/stop cycles
- Total operating hours
- Reactor temperature
- Wiper status

Simple view will display:

- Power level
- UV Intensity
- Total start/stop cycles
- Total operating hours
- Reactor temperature
- Wiper Status

First Lamp Start-Up

Starting up the UV system can be done from:

- HMI
- With a 24V signal
- From Modbus
- From PROFINET/Profibus

This example will cover startup from HMI, the startup sequence is identical in all startup modifications.

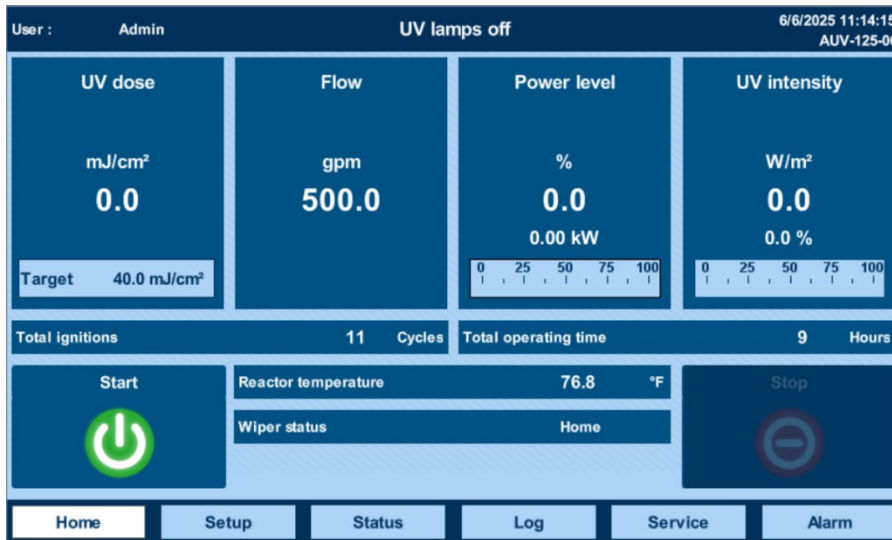

On the main screen the operator will find the most necessary information. It is also from here where the system is started and stopped manually.

The START in the bottom left corner is highlighted when the system is stopped. This means that the button can be pressed to start the system.

When the START button is pressed it will no longer be illuminated.

The STOP button is in the bottom right corner and is not illuminated when the system is stopped. This means that the button cannot be pressed.

When the system is started/running the STOP button becomes illuminated and active so the system can be stopped.

When start is activated, the following sequence will start:

- After 5 seconds the system will initiate the start sequence.
- The "UV LAMPS OFF" text will change to "SYSTEM STARTING" and the power level will change to 100%.
- When one or more lamps is turned on the "SYSTEM STARTING" text will change to "SYSTEM WARMING UP".
- The FLOW relay will activate if all the requirements are met after the time delay has expired, and the warmup phase will have finished.
- When the warmup phase has finished the "SYSTEM WARMING UP" text will change to "LAMPS ON".
- For the next 10 minutes the UV system will run at 100% power level and cannot be dimmed.
- Once 10 minutes expires the system will either reduce power level or keep running at 100% depending on water quality and if "Auto dimming" has been selected on in the setup menu "UV DOSE".

Stop the UV System

When stop is activated, the follow sequence will start:

- The system will turn off the lamps almost immediately.
- A timer will start to prevent startup right after shutdown.
- This is to ensure proper cooldown of the lamps before reignition.
- The timer is set by default to 5 minutes by Aquify and minimum setpoint is 1 minute.

If start is activated within the 5-minute timer the “UV LAMPS OFF” text will change to “SYSTEM STARTING IN:” and then the remaining time will be shown in seconds.

Control System Preparation

Control system is delivered with factory settings. It is recommended not to change these settings without consulting an Aquify representative beforehand.

A few settings must be set locally prior to startup or during startup process as they depend on local conditions.

IMPORTANT!

ESPECIALLY AFTER STARTING WATER FLOW, AIR BUBBLES MAY DEVELOP ON ALL SURFACES INSIDE THE REACTOR. THIS INCLUDES QUARTZ SLEEVES AND UV-SENSOR MEASURING PORT WINDOWS. IN CASE OF SUCH BUBBLES, UV-SENSOR READINGS MAY BE SIGNIFICANTLY REDUCED. IF THE SYSTEM IS EQUIPPED WITH QUARTZ SLEEVE CLEANING SYSTEM, A CLEANING CYCLE HELPS TO REMOVE ATTACHED BUBBLES.

Values will be a result of fouling, debris on quartz sleeves and sensor measuring port, reduced water transmittance or malfunction.

Set UVI 100% Reference

When first starting up the system it is important to set the UVI 100% reference.

This is done to get a starting point of the UV intensity so it's easy to monitor over time and to determine when cleaning or service is required.

Password Access

The UV system has password protection on most of the menus and parameters. This is to ensure that only qualified personnel are adjusting or controlling the UV system.

Username = admin
Password = 0001

Set System Time

Set the UV system time so that all alarms and trend views have the correct timestamp. To set the time please refer to page 30 in the manual.

CONTROL PANEL MENUS

The Aquify UV system is controlled by a Siemens S7-1200 PLC with a Siemens KTP700 HMI screen. The operator can through the HMI screen control and monitor the system as well as change different parameters.

HMI Navigation

When using the HMI screen, it is recommended to use the non-writing end of a pen or a similar instrument. Some entry fields on the HMI are designed with touch areas too small to be pressed with most fingertips. Avoid using excessive force when pressing the HMI screen.



The screen navigation bar shown on the picture above lets the operator navigate throughout the different menus.

Set System Time

To set the system time, go to the home screen.

Press the time display in the top right corner on the HOME screen. This will activate the time setup screen.

Follow these steps to set the system time:

- Press the “Set time mode” button
- Press the time display in the middle of the screen and enter the current time in the shown time format

It is important to use the same time format as shown in the display.

- Press the “Confirm” button
- Press the “Set time mode” button again to exit the set time mode



Home Screen

When using the HMI screen, it is recommended to use the non-writing end of a pen or a similar instrument. Some entry fields on the HMI are designed with touch areas too small to be pressed with most fingertips. Avoid using excessive force when pressing the HMI screen.

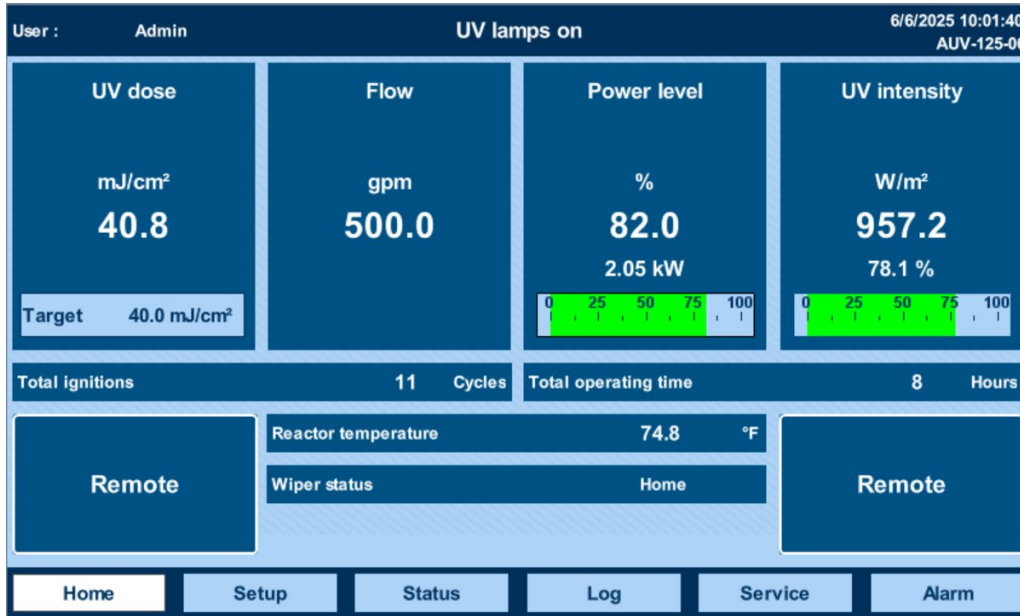

DISPLAY	DESCRIPTION
UV dose	Calculated UV dose in mJ/cm2
Flow	Actual water flow.
Power level	Power level of UV system in % as well as a fill bar 0-100%. The power level is also shown in kW of the actual power usage
UV intensity	UVI in W/m2 as well as fill bar 0-100%
Total start/stop cycles	Displays how many times the UV system has been started
Total operating hours	Displays how many hours the UV lamps has been turned ON
Reactor temperature	Temperature of the reactor
Wiper status	The status of the wiper
UVT	The value of water UVT (Only Visible if UVT is enabled)

Set-Up - Operation Screen

User : Admin		UV lamps off		6/6/2025 11:16:50 AUV-125-06	
Operation	Operation mode			Local	
Temperature	Control mode			Manual	
UV sensor	Power setpoint	100.0	%	Local	
UV dose	Safety circuit 1 function			Alarm + lamp off ▼	
Analogue	Safety circuit 2 function			Alarm + lamp off ▼	
System relays	Safety circuit on delay	10		Sec	
Ultrawiper™	Safety circuit off delay	10		Sec	
	Flow signal delay	300		Sec	
	Lamp shut off delay	15		Sec	
	Ignition cycle delay	5		Min	
Home		Setup		Status	
		Log		Service	
				Alarm	

DISPLAY	DESCRIPTION
Operation mode	Choose from where the system is started, possible selections: <ul style="list-style-type: none"> Local Remote Modbus & PROFINET
Control mode	Choose between the following selections: <ul style="list-style-type: none"> Manual - Power level is fixed and adjusted manually Automatic - Power level is adjusted automatically according to calculated UV Dose Time Schedule - UV system is controlled according to a weekly plan for power level or On/Off timestamps
Power setpoint	Sets the power setpoint if "Control mode" is set to Manual.
Safety circuit 1 & 2 functions	The operator can choose what the consequence will be when either safety circuit 1 or 2 is broken, possible selections: <ul style="list-style-type: none"> Alarm + Lamp off Alarm
Safety circuit ON delay	Time setpoint for how long before the system registers the safety circuits has been closed.
Safety circuit OFF delay	Time setpoint for how long before the system registers the safety circuits has been broken.
Flow signal delay	Time setpoint that determines how long after start has been pressed, when the flow relay will close.
Lamp shut off delay	Time setpoint that determines how long after stop is pressed, the lamps will shut off.
Ignition cycle delay	Time setpoint determines how long after lamps have been shut down, that the UV lamps can be started again. This can also be seen as the cool down time.

Set-Up - Time Schedule

User : Admin		UV lamps off				6/6/2025 11:18:00 AUV-125-06	
Operation	Time schedule mode	Power					
Temperature		Time 1	Power 1	Time 2	Power 2		
UV sensor	Monday	0.00	0	0.00	0		
UV dose	Tuesday	0.00	0	0.00	0		
Analogue	Wednesday	0.00	0	0.00	0		
System relays	Thursday	0.00	0	0.00	0		
Ultrawiper™	Friday	0.00	0	0.00	0		
	Saturday	0.00	0	0.00	0		
	Sunday	0.00	0	0.00	0		

The Time Schedule mode lets the operator set weekly timestamps for different power levels or on/off cycles.

Please note that the Time Schedule Mode still requires an active start of the UV system. It is first when the start signal is activated, and the system is running, that the below mentioned modes are active.

Time schedule mode:

Let's the operator switch between changing of power, or on/off.

Power:

- Let's the operator set specific power setpoints for the specified timestamps

Example: Picture above shows an example of how a weekly schedule could be.

- On Monday the system will run at 100% power from 12:00 o'clock and change power to 60% at 17:00 o'clock
- The system will keep running at 60% until Tuesday at 10:00 o'clock when it will change to 100% power again

On/Off:

- Let's the operator set different ON and OFF timestamps for the system

Example: Picture below shows an example of how a weekly time schedule could be.

- On Monday at 12:00 o'clock the system will be ON and then it will turn OFF at 17:00 o'clock. The UV system will stay off until Tuesday at 10:00 o'clock when it will turn ON again.

User : Admin		UV lamps off				6/6/2025 11:18:51 AUV-125-06	
Operation	Time schedule mode	On/Off					
Temperature		Time 1	On/Off	Time 2	On/Off		
UV sensor	Monday	0.00	OFF	0.00	OFF		
UV dose	Tuesday	0.00	OFF	0.00	OFF		
Analogue	Wednesday	0.00	OFF	0.00	OFF		
System relays	Thursday	0.00	OFF	0.00	OFF		
Ultrawiper™	Friday	0.00	OFF	0.00	OFF		
	Saturday	0.00	OFF	0.00	OFF		
	Sunday	0.00	OFF	0.00	OFF		

Set-Up - Temperature Screen

User : Admin		UV lamps on		6/6/2025 10:02:51 AUV-125-06	
Operation	Restart after alarm			<input type="radio"/> OFF	
Temperature	Reactor temperature 1	75.0	°F		
UV sensor	Reactor temperature 2	74.5	°F		
UV dose	Temperature alarm	110.0	°F		
Analogue	Temperature pre-alarm	104.0	°F		
System relays	Temperature deviation alarm	50.0	°F		
Ultrawiper™	Temperature unit			<input type="radio"/> °F	
<div style="display: flex; justify-content: space-between; padding: 5px;"> Home Setup Status Log Service Alarm </div>					

DISPLAY	DESCRIPTION
Restart after alarm	<ul style="list-style-type: none"> On - When "Restart after alarm" is selected ON, then the system will automatically start after a temperature alarm, given that the temperature has reached 3°F/2°C below the pre-alarm OFF - When "Restart after alarm" has been selected OFF, then the system requires a manual reset of the temperature alarms
Reactor temperature 1	Actual temperature reading
Reactor temperature 2	Actual temperature reading
Temperature alarm	When the temperature reaches this set point the system will shut down. This is to protect the system against overheating in case air pockets have formed inside the reactor.
Temperature pre-alarm	The pre-alarm setpoint triggers an alarm that lets the operator know that the temperature is increasing
Temperature unit	Sets the temperature unit between Fahrenheit and Celsius

****NOTE:**** It's only possible to reset the temperature alarm & pre-alarm once they have reached their setpoint minus 3°F/2°C.

Example:

Setpoint = 95°F/35°C

The actual temperature needs to be below 92°F/33°C before a temperature alarm reset can happen. This is done to ensure that the temperature does not trigger the alarm right after it has been reset.

Set-Up - UV Sensor Screen

User : Admin		UV lamps on		6/6/2025 10:04:24 AUV-125-06	
Operation	No# UV sensors installed		1		
Temperature	UV intensity	957.1		W/m ²	
UV sensor	UVI 100 % reference	1225.0		W/m ²	
UV dose					
Analogue					
System relays	Enable UV intensity alarms			YES	<input checked="" type="checkbox"/>
Ultrawiper™	UV intensity alarm	150.0		W/m ²	
	UV intensity pre-alarm	300.0		W/m ²	
	UVI Alarm delay	5		Sec	

DISPLAY	DESCRIPTION
No# UV sensors installed	Number of UV sensors installed in the system
UV intensity	Actual UV intensity reading
Sensor 1 UV intensity	Actual UV Intensity reading from Sensor 1
UVI 100% reference	Is the reference percentage to the actual UV intensity reading
Enable UV intensity alarms	Enables/disables UV intensity alarms
UV intensity alarm	When the UV intensity is below this setpoint an alarm will be triggered
UV intensity pre-alarm	The pre-alarm setpoint triggers an alarm that lets the operator know that UV Intensity is decreasing

****NOTE:**** It's only possible to reset the UV intensity alarm & pre-alarm once they have reached their setpoint plus 10 W/m².

Example:

Setpoint = 50 W/m²

The actual UV intensity needs to be above 60 W/m² before the alarm reset can happen.

This is done to ensure that the UV Intensity does not trigger the alarm right after it has been reset. The same principle is applied to the Deviation alarm, only here it is: setpoint + 2 W/m².

Set-Up - UV Dose Screen

User : Admin		UV lamps on		6/6/2025 10:24:05 AUV-125-06	
Operation	Current UV dose	41.4		mJ/cm ²	
Temperature	Target UV dose	<input type="text" value="40.0"/>		mJ/cm ²	
UV sensor	Dimming offset	<input type="text" value="5.0"/>		%	
UV dose	Dimming deadband	<input type="text" value="2.0"/>			
Analogue					
System relays					
Ultrawiper™	Enable UV dose alarms			YES	<input checked="" type="checkbox"/>
	UV dose alarm	<input type="text" value="30.0"/>		mJ/cm ²	
	UV dose pre-alarm	<input type="text" value="35.0"/>		mJ/cm ²	
	UV dose alarm delay	<input type="text" value="5"/>		Sec	
Home	Setup	Status	Log	Service	Alarm

DISPLAY	DESCRIPTION
Current UV dose	The current UV Dose delivered by the system
Target UV dose	The target UV Dose the system will try to uphold when set to automatic
Dimming offset	The dimming offset is a %-margin of how close the system will reduce the UV Dose to the UV Dose setpoint Example: The dimming setpoint is set to 10% <ul style="list-style-type: none"> • Target UV dose is set to 50 mJ/cm² • The system will try to uphold a UV dose of 55 mJ/cm²
Dimming deadband	Is added/subtracted from the Target UV dose and acts as an area where the dimming is not active
Enable UV dose alarms	Enables/disables UV dose alarms
UV dose alarm	When the UV dose is below this setpoint an alarm will be triggered
UV dose pre-alarm	The pre-alarm setpoint triggers an alarm that lets the operator know that UV dose is decreasing

Set-Up - Analogue Flow

User : Admin		UV lamps on		6/6/2025 10:24:58 AUV-125-06	
Operation	Flow	Output	UVT	CC	
Temperature	Flow setpoint	Manual			
UV sensor	Current flow	500.0	m ³ /h		
UV dose	Enter expected max flow	500.0	m ³ /h		
Analogue					
System relays	Divide flow factor	1.0			
Ultrawiper™	Flow input unit	gpm			
	Min. allowed flow	0.0	m ³ /h	☐☐☐	Off
	Max. allowed flow	0.0	m ³ /h	☐☐☐	Off
Home	Setup	Status	Log	Service	Alarm

The analogue menu consists of submenus where the flow menu is opened first.

These menus are related to the analogue inputs/outputs of the UV system, and any configuration to these are done in here.

DISPLAY	DESCRIPTION
Flow origin	Determines where the flow setpoint is coming from <ul style="list-style-type: none"> • Manual – Manually enter an expected maximum flow • 4-20mA – Connect an analogue 4-20mA flow meter • Modbus – Send flow value via Modbus • Put/Get – Send flow value via Put/Get protocol • PN/PN – Send flow value via PN/PN protocol • IDevice – Send flow value via IDevice protocol
Current flow	Shows the current flow value
Divide flow factor	Divides flow
Flow input unit	Changes the unit of the flow input <ul style="list-style-type: none"> • m³/h – flow input to PLC is m³/h • gpm – Flow input to PLC is gpm • L/s – Flow input to PLC is L/s
Min allowed flow	Alarm for minimum allowed flow, this can be enabled or disabled accordingly
Max allowed flow	Alarm for maximum allowed flow, this can be enabled or disabled accordingly

****NOTE:**** The minimum allowed flow has a 2-minute delay after the FLOW signal is activated.

This is to allow flow to slowly increase and prevent immediate activation of the minimum flow alarm.

Set-Up - Analogue Output

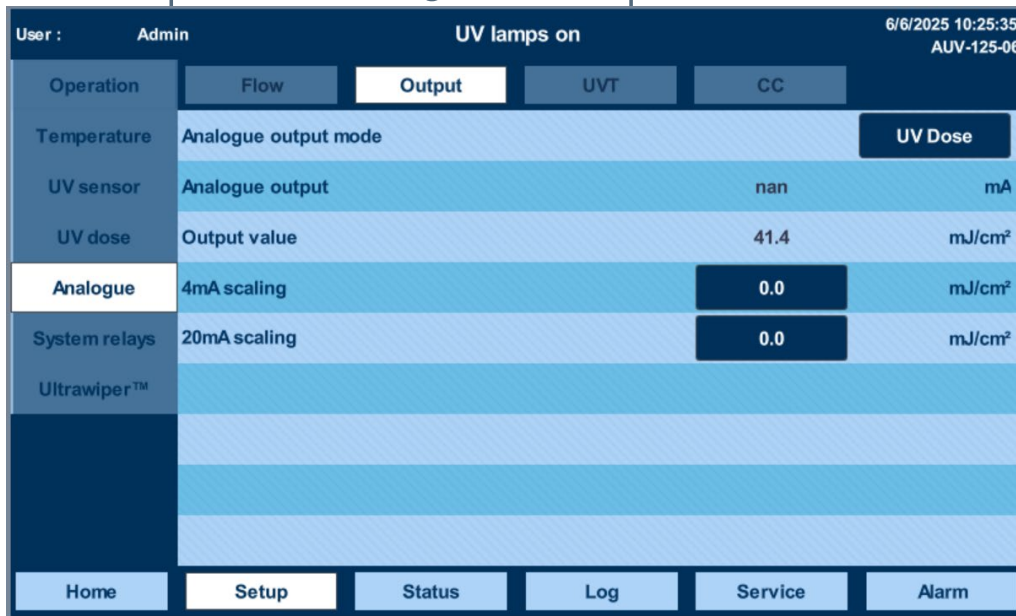

The analogue menu allows the operator to select the output parameter of the analogue output.

The analogue output is a 4-20mA signal and can be scaled according to different parameters.

DISPLAY	DESCRIPTION
Analogue output mode	Determines which parameter is selected for the analogue output. <ul style="list-style-type: none"> UV Dose – The analogue output will be configured to display the calculated UV dose UVI – The analogue output will be configured to display the UV intensity UVI Ref – The analogue output will be configured to display the UVI reference value Power Level – The analogue output will be configured to display the current power level of the UV system
Analogue output	Shows the milliamperage from the analogue output
Output value	Shows the current value of the selected output parameter
4mA scaling	Scales the lower end of the analogue output. This should in most cases be zero
20mA scaling	Scales the higher end of the analogue output

Set-Up - Analogue UVT

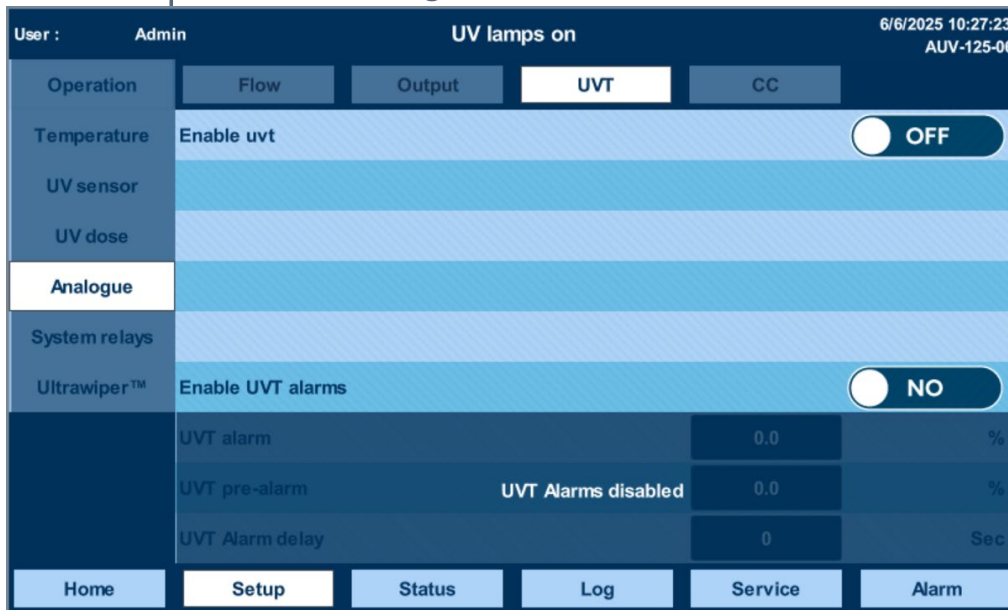

The UVT menu is a simple menu related to the UVT analogue input.

DISPLAY	DESCRIPTION
Enable UVT	Enables the UVT function in the UV system
UVT	Displays the actual UVT
Enable UVT alarms	Enables alarms and alarm delay related to the UVT input
UVT alarm	Is the setpoint for UVT alarm
UVT pre-alarm	Is the setpoint for UVT pre-alarm
UVT alarm delay	Is the added delay to the UVT alarms

Analogue Combined Chlorine

User : Admin UV lamps on 6/6/2025 10:30:06
 AUV-125-06

Operation	Flow	Output	UVT	CC
Temperature	Enable Combined Chlorine			<input type="checkbox"/> OFF
UV sensor	Combined Chlorine		0.0	mg/l
UV dose	4 mA		0.0	mg/l
Analogue	20 mA		0.0	mg/l
System relays				
Ultrawiper™				
	Enable Combined Chlorine control			<input type="checkbox"/> NO
	Combined Chlorine High level		0.0	mg/l
	Combined Chlorine control disabled			
	Combined Chlorine Low level		0.0	mg/l

Home Setup Status Log Service Alarm

Set-Up - System Relays

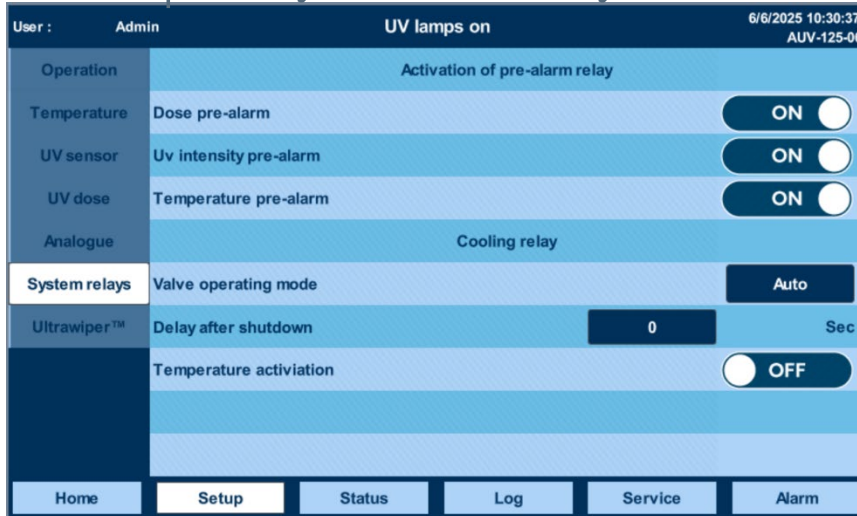

Activation of pre-alarm relay

The System Relays screen allows the operator to disable a few selected alarms from activating the alarm relays. For example. If the Dose Pre-alarm is set to “ON” the alarm will activate the pre-alarm relay. If the Dose Pre-alarm is “OFF” the alarm will NOT activate the pre-alarm relay.

Cooling relay

The valve control screen gives the operator control over the cooling valve. The cooling valve is designed to keep water circulating inside the reactor during warm up and after lamp shut down.

The cooling valve has three operating modes:

Valve control : Auto



When giving the system the start signal, the cooling valve will automatically open during the warmup period until the FLOW relay activates allowing water to flow through the reactor.

When giving the system the stop signal, the cooling valve will again open for a specified amount of time. This time is entered in the HMI in seconds in the setpoint called “Delay after shutdown”.

Valve control : Manual



In manual mode, the cooling valve is manually operated by the operator.

Valve control : Remote



In remote control the cooling valve is operated via. Communication – Modbus, PROFINET or Profibus.

Set-Up - Wiper

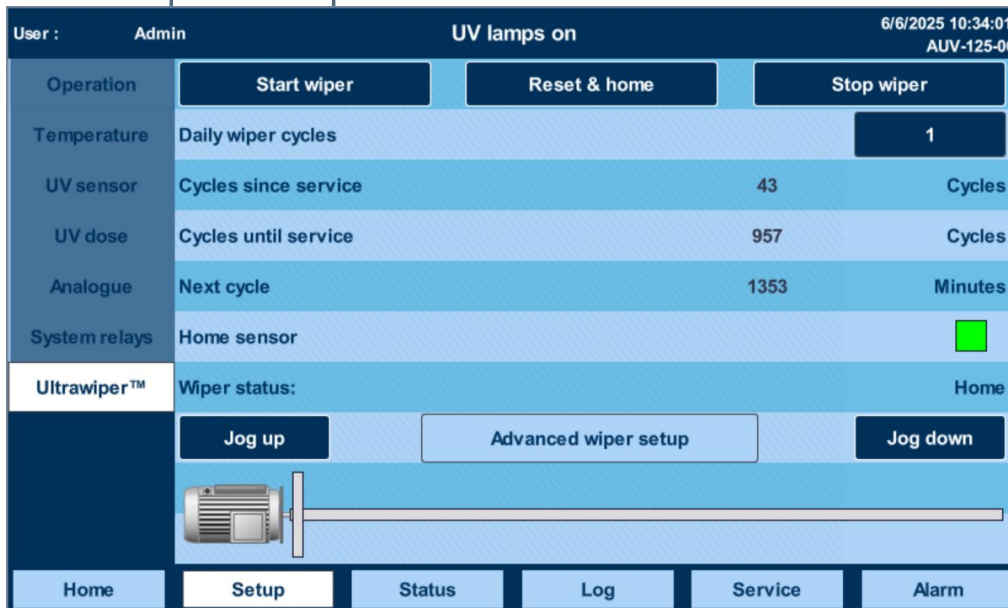

DISPLAY	DESCRIPTION
Daily wiper cycles	Determines the number of cycles the wiper will automatically perform each day. <ul style="list-style-type: none"> If this is set to 100 the wiper will run continuously
Cycles since service	The number of cycles that have been performed since the wiper system was serviced
Next cycle	The time until the next wiper cycle
Home sensor	This sensor will change to green when the wiperplate is in the home position.
Wiper status	Displays the following: <ul style="list-style-type: none"> Extracting – The wiperplate is moving towards the end position Retracting – The wiperplate is moving toward the home position Home – The wiperplate is at home Homing – The wiperplate is returning home after a fault Fault – A fault has occurred
Jog up	This button will activate the motor manually to move towards the home position
Jog down	This button will activate the motor manually to move towards the end position

As the wiper is an important part of the UV system, it is equally important that the operator knows how the wiper works. When the UV cabinet is powered on i.e., when the PLC enters RUN mode, the wiper always returns to home position if not already there.

The wiper is set by default to run one time each day but can be changed if water quality is worse than expected and quartz sleeves are fouling faster than expected.

Manual Start of Wiper

Start is pressed the following sequence will happen:

- An internal timer of 3 seconds will begin count down
- Countdown is finished, the motor will turn clockwise and push the wiperplate towards the bottom
- The “Wiper Status” will change from “Home” to “Extracting”
- When the wiperplate reaches the end, it will stop and wait for 3 seconds
- When 3 seconds have passed, it will begin to turn counterclockwise and pull wiperplate back to home position
- The “Wiper Status” will change from “Extracting” to “Retracting”
- It will continue to run until it reaches the Home Sensor which will activate when the wiperplate is near it
- The “Wiper Status” will change from “Retracting” to “Home”

Manual Stop of Wiper

It is possible to stop the wiper at any time by pressing the button “Stop”. When Stop is pressed the following will happen:

- The motor will immediately stop its motion
- The “Wiper Status” will change to “Stopped”

To start the wiper system again, simply press “Start cycle” and it will continue from last action.

Reset the Wiper

When a fault with the wiper system occurs the “Wiper Status” will change to “Fault”.

When the fault has been resolved press the “Reset & Home” button and the following will occur:

- Clear and reset any alarms in the alarm menu
- The power will shut off to the motor controller card for 5 seconds, then begin to drive the motor to return the wiperplate to the home position
- The “Wiper Status” will change to “Homing”

User : Admin		UV lamps on		6/6/2025 10:34:58	
				AUV-125-06	
Operation	Pulse counter			0	
Temperature	Max pulse counter			70	
UV sensor	Max cycle time	10	Minutes		
UV dose	Pulse signal alarm delay	12	Sec		
Analogue	Passing of uv sensor delay	45	Sec		
System relays	Service position pulse	Service position	42		
<div style="border: 1px solid black; padding: 5px;"> Ultrawiper™ </div>					
					
Home		Setup	Status	Log	Service
					Alarm

Advanced Wiper Set-Up

DISPLAY	DESCRIPTION
Pulse counter	The current number of rotations the motor has performed.
Max pulse counter	The setpoint for where the motor will change direction and begin to return to its home position.
Max cycle time	The amount of time each cycle is allowed to take. If this time is exceeded a fault with the wiper system has likely occurred and an alarm will be triggered.
Pulse alarm signal delay	Allowed time between each pulse signal before alarm triggers.
Passing of UV sensor delay	An added delay on the UVI alarms + UV Dose alarms when wiper is running
Service position pulse counter	The setpoint for the recommended position of the wiperplate when changing the quartz sleeves (It is usually set to half of the max pulse counter setpoint)
Service position button	Activates the motor to the service position

User : Admin
UV lamps on 6/6/2025 10:34:58
AUV-125-06

Operation	Pulse counter	0
Temperature	Max pulse counter	70
UV sensor	Max cycle time	10 Minutes
UV dose	Pulse signal alarm delay	12 Sec
Analogue	Passing of uv sensor delay	45 Sec
System relays	Service position pulse	<input type="button" value="Service position"/> 42
Ultrawiper™		
<div style="position: relative; width: 100%; height: 100%;"> ← </div>		
Home	Setup	Status
Log	Service	Alarm

Status - Overview Screen

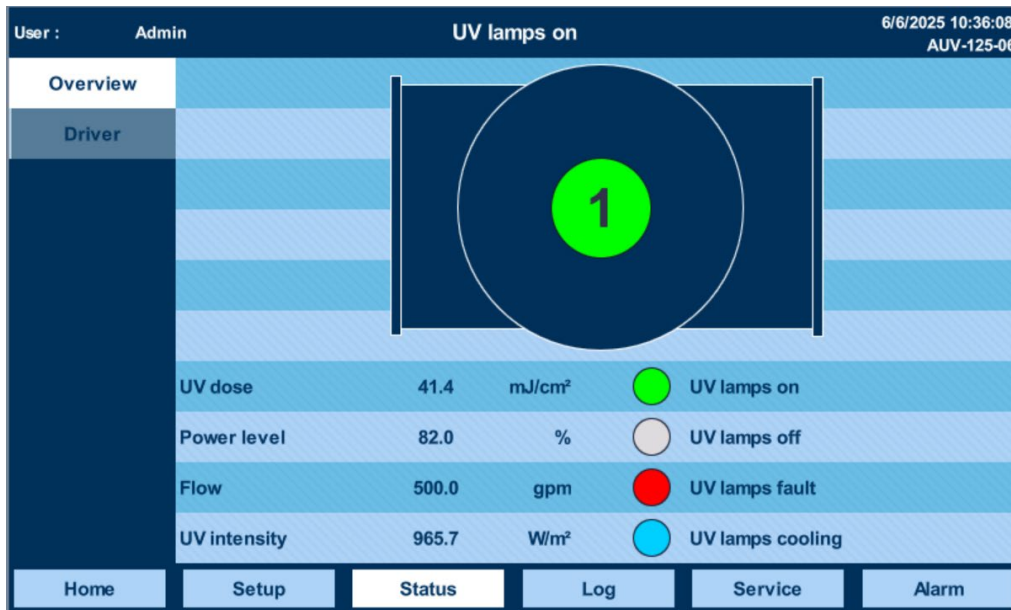

The Lamp Overview screen is used if the operator wants to get a visual overview of the individual UV Lamps in the reactor. Each individual circle represents a UV Lamp in the reactor and changes color according to the status of the lamp.

The colors represent the following:

- Green – UV Lamp ON
- Grey – UV Lamp OFF
- Red – UV Lamp Fault
- Blue – UV Lamp Cooling

Important information such as UV Dose, power level, UV Intensity and flow is also shown on the Lamp Overview screen. This makes it possible to monitor all important values and statuses at the same time.

Status – Driver Screen

User : Admin		UV lamps on		6/6/2025 10:36:41 AUV-125-06	
Overview	System ok ●	Intake air temp fault ○	Lamp 5min. below 85% ○		
Driver	Lamp driver ok ●	Input voltage fault ○	Internal voltages ○		
	Data range ok ●	Heatsink temp fault ○	Fan fault ○		
	Lamp open ○	Lamp 2min. below 85% ○	Protect fault ○		
	Lamp short ○	Comm Error ○			
Driver					
#	1				
Next	Amperage	6.645A	Voltage	335V	Power 2050W
Previous	Lamp ok ●	Lamp on ●	Lamp reignite ○		
Home	Setup	Status	Log	Service	Alarm

Monitoring

The driver status screen is a monitoring tool for the operator to help verify that each driver within the system is operating as intended.

- The driver is type 600W, the driver monitoring feature is currently unavailable
- The driver is type 2500W, one or two lamps will be installed and shown
- The driver is type 4000W, two or three lamps will be installed and shown

Data from each lamp output is available.

- Amperage [A] – The amount of amperage the lamp is using
- Voltage [V] – The amount of voltage the lamp is using
- Power [W] – The amount of power the lamp is using

Other indicators are available to help verify that the system is healthy (GREEN) or unhealthy (RED):

- Lamp OK
- Data Range OK
- System OK
- Lamp Driver OK

The operator is free to navigate through the lamp driver using the two buttons “Next” and “Previous”. It is also possible to enter a specific lamp driver number in the display for quicker navigation.

Troubleshooting

This screen can help the operator troubleshoot the system when a driver fault/lamp fault occurs. When a driver fault occurs, an alarm will be triggered and shown in the alarm list. This will display “Driver Fault X”.

The operator can then go to the Driver Status screen and see which alarm is causing the driver to malfunction. The driver alarms will be explained more in chapter “System alarms”.

If a Lamp fault occurs the “Lamp OK” indicator will be red, indicating that something is wrong with the lamp. When an alarm is present the circle will be red and when no alarm is present the circle will be gray.

Log – Logging Screen

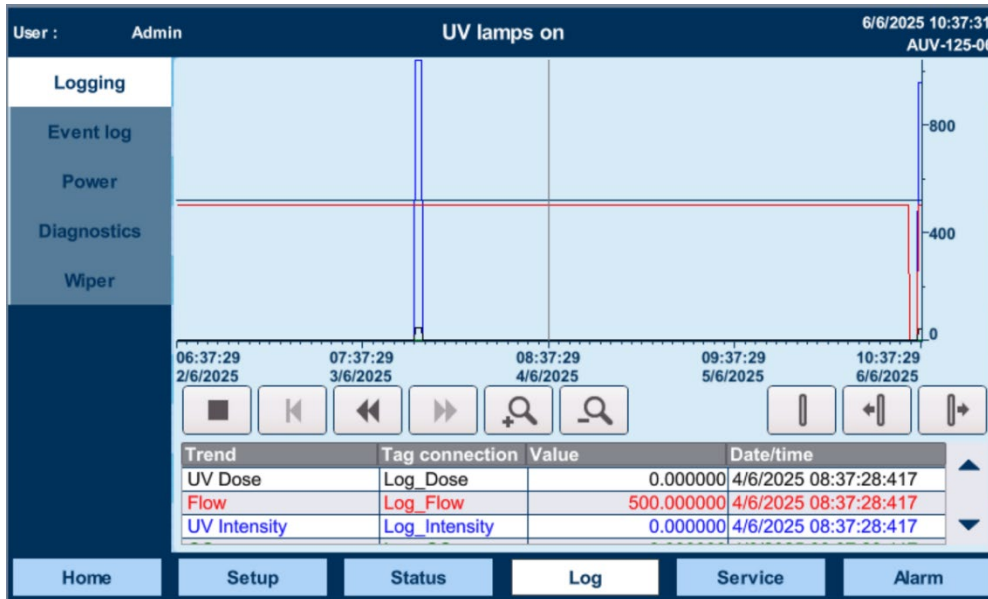

****NOTE:**** The logging function is only active if a USB is placed in the back of the screen.

The logging screen shows a trend view of:

- UV Dose
- UV Intensity
- Flow

These three data points are logged every 10 minutes onto the USB.

It is possible to use the touch display to move the trend view, as well as use the different functions in the trend view. The trend view does not update when the logging screen is active. The operator will need to exit the screen and re-enter the screen to see any updates.

Trend view ruler



Press the LEFT button to activate the ruler onto the graph.

This will then show the value for UV Dose, Flow and UV Intensity at that moment where the Ruler is placed.

It is then possible to move the ruler, either by dragging it on the touch display, or pressing either the MIDDLE or RIGHT button.

Trend view zoom



Use the Zoom buttons to increase or decrease the visible timeline (X-axis).

Log – Event Log Screen

User : Admin		UV lamps on		6/6/2025 10:38:06
		AUV-125-06		
	Time	Date	Status	Text
Logging	09:44:03	6/6/2025	I	Uv lamp control from terminal (remote) ...
Event log	10:13:23	5/6/2025	IO	Uv lamp control from terminal (remote) ...
	10:10:32	5/6/2025	I	Uv lamp control from terminal (remote) ...
Power	14:43:19	3/6/2025	IO	Uv lamp control from terminal (remote) ...
	14:22:55	3/6/2025	I	Uv lamp control from terminal (remote) ...
Diagnostics	11:26:34	3/6/2025	IO	Uv lamp control from terminal (remote) ...
	10:41:17	3/6/2025	I	Uv lamp control from terminal (remote) ...
Wiper	10:33:57	3/6/2025	IO	Uv lamp control from terminal (remote) ...
	12:55:47	13/5/2025	IO	Uv lamp control from hmi (local) ...
	12:29:54	13/5/2025	I	Uv lamp control from hmi (local) ...
	11:34:47	3/5/2025	IO	Uv lamp control from hmi (local) ...
	10:00:12	3/5/2025	I	Uv lamp control from hmi (local) ...
	11:59:33	1/5/2025	IO	Uv lamp control from hmi (local) ...
	11:05:20	1/5/2025	I	Uv lamp control from hmi (local) ...
	16:41:18	29/4/2025	IO	Uv lamp control from hmi (local) ...
	15:20:57	29/4/2025	I	Uv lamp control from hmi (local) ...
	13:02:33	25/4/2025	IO	Uv lamp control from hmi (local) ...
	10:13:45	25/4/2025	I	Uv lamp control from hmi (local) ...
	08:55:30	23/4/2025	I	Uv lamp control from put/get (putget) ...

The System Event screen shows whenever the system has been started and stopped.

The column named Status shows what happens with the event.

- Status = I – means it is an action that has been initiated (IN)
- Status = IO – means it is an action that has been stopped (OUT)

Log – Power Screen

User : Admin		UV lamps on		6/6/2025 10:38:39	
Logging	Current power consumption		2.05	kW	
Event log					
Power	Current year kWh		1.91	kWh	
Diagnostics	Last year kWh		0.00	kWh	
Wiper	January	0.00 kWh	July	0.00 kWh	
	February	0.00 kWh	August	0.00 kWh	
	March	0.00 kWh	September	0.00 kWh	
	April	0.00 kWh	October	0.00 kWh	
	May	0.00 kWh	November	0.00 kWh	
	June	1.91 kWh	December	0.00 kWh	
Home	Setup	Status	Log	Service	Alarm

The power menu gives a quick overview of the UV systems' power usage.

DISPLAY	DESCRIPTION
Current power consumption	Displays the current kilowatts the system is using
Current year kWh	Displays the accumulated kWh used in the current year
Last year kWh	Displays the accumulated kWh used in the previous year

When the year changes the “Current year kWh” will be moved into the “Last year kWh”.

Log - Diagnostics Screen

Below is an overview of each month and the amount of kWh used in the respective month.

****NOTE:**** It is important that the system time is set correctly according to the local time zone in order for the kWh calculation to function properly.

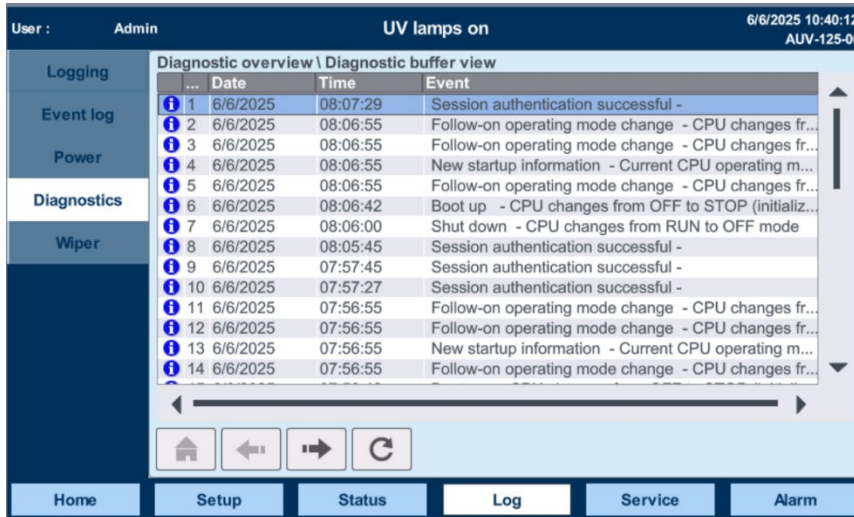

The diagnostics overview can help the operator in situations where the PLC malfunctions.

If something has happened to the I/O cards, inputs etc., the Diagnostic view can then help to identify what output/input is the cause of error and also give possible reasons for the error occurrence.

Example:

If we look at the “Wire Break” message, then the diagnostic view indicates which module and where the input error is located.

- K1:1 Unimulti is the PLC
- K1:4 is the analogue input module

Below displays the possible causes of the error.

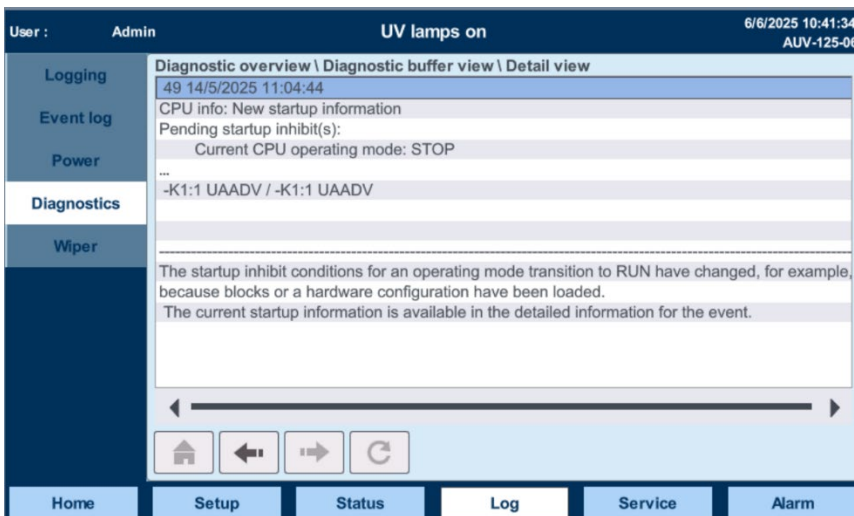

Log - Wiper Current

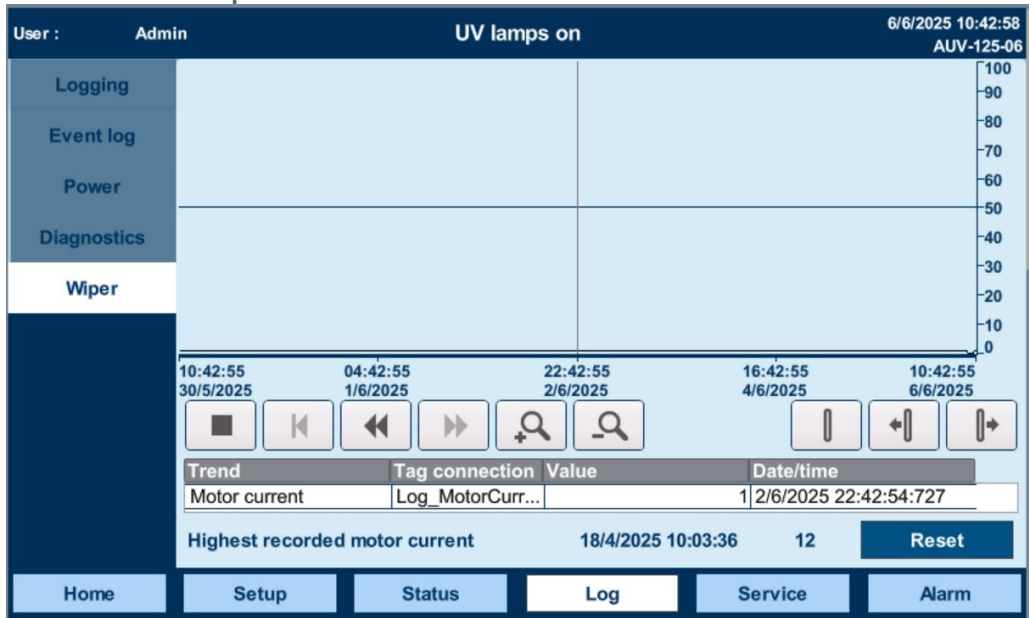

This screen monitors changes in the wiper current resistance over time.

- An increase in wiper current may indicate that the fouling on the quartz sleeves is worsening

The system will also log the highest recorded motor current and the time of occurrence.

- This is used to identify and spikes in motor current and correlate the with potential system failures

Service - UV Lamps

User : Admin		UV lamps on		6/6/2025 10:43:34 AUV-125-06	
UV lamps	#1	8968	<input type="checkbox"/>		
Quartz sleeve					
UV sensor					
Ultrawiper™					
Wizard					
Select all					
Reset					
Home	Setup	Status	Log	Service	Alarm

The hour counter of the specific UV lamp **MUST** be reset any time a lamp is replaced. Use this menu, when it is possible to select the specific UV lamp and only reset the hour counter attached to the lamp being replaced.

- Select all – Selects all UV Lamps so not to press all individual lamps
- Reset – Starts reset process

Service - Quartz Sleeves

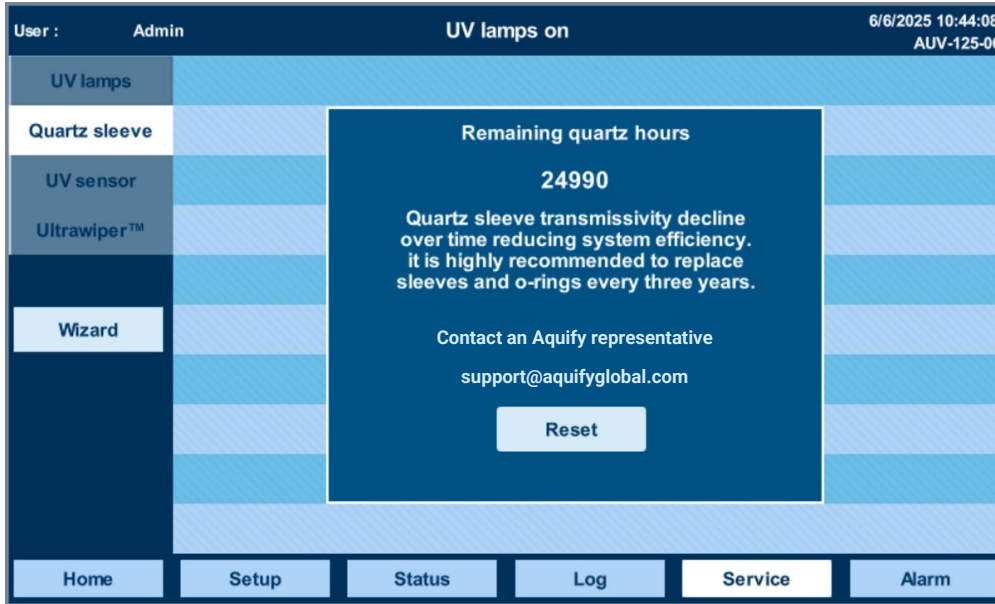

The screenshot shows a web interface for 'UV lamps on' with the user 'Admin'. The page title is 'Service - Quartz Sleeves'. The main content area displays 'Remaining quartz hours' as 24990. Below this, a message states: 'Quartz sleeve transmissivity decline over time reducing system efficiency. it is highly recommended to replace sleeves and o-rings every three years.' A 'Reset' button is visible. The footer contains navigation links: Home, Setup, Status, Log, Service, and Alarm.

A single hour counter is used for the quartz sleeve(s).

The quartz sleeves are usually only replaced if they are broken, or if the lifetime has been exceeded.

Service - UV Sensor

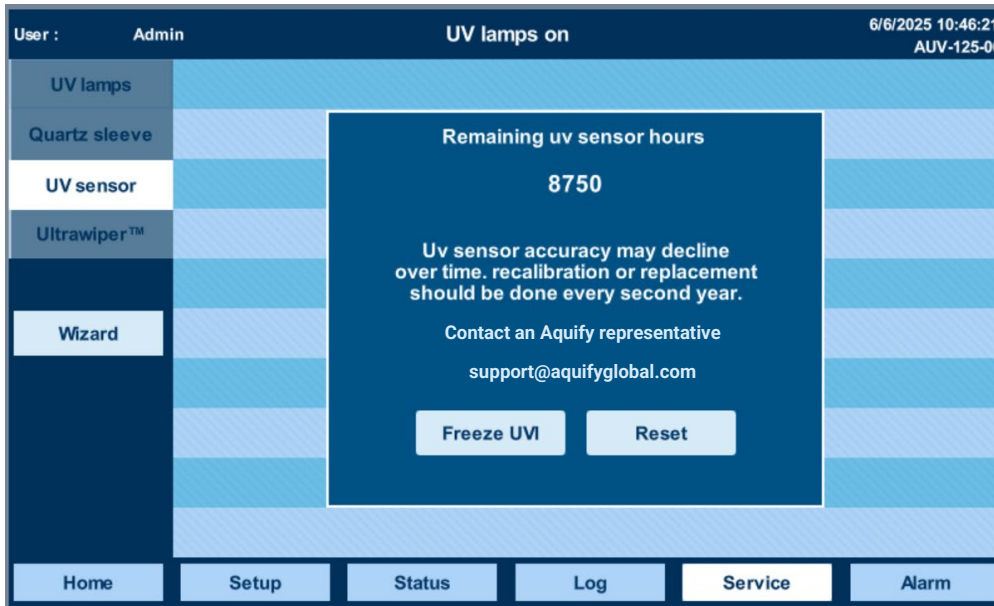

The UV sensor has an individual hour counter

- It is recommended to calibrate or replace the sensor once each year

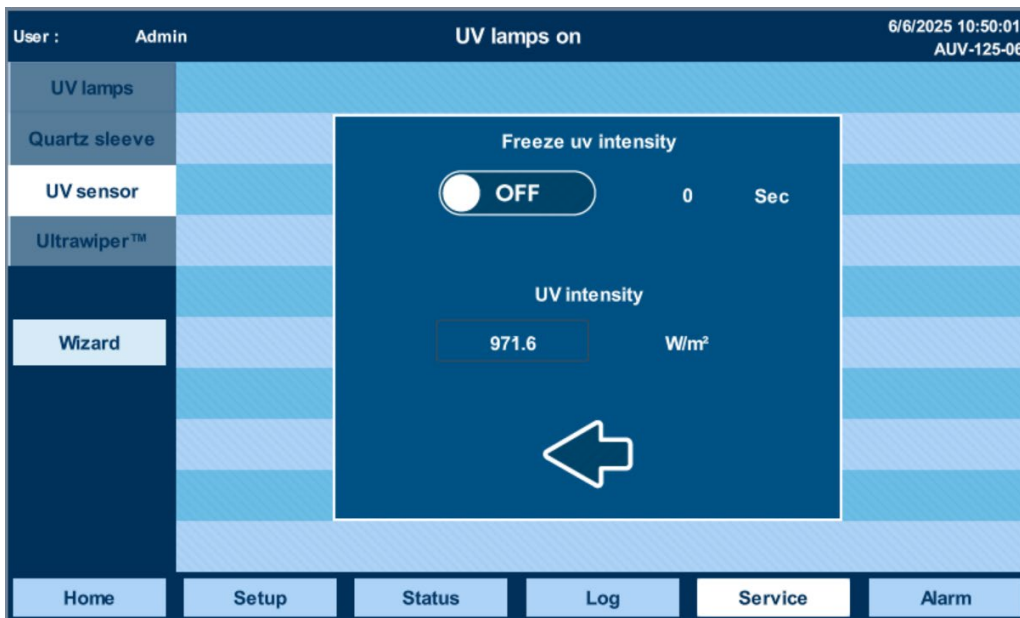

It is possible to freeze the UV intensity for 600 seconds (10 minutes) if needed.

This can be in situations where the value from UV sensor is compared to a reference UV sensor. Then you must first freeze the UV intensity and then take out the UV sensor.

Afterwards you can insert the reference UV sensor and compare the two values.

Service - Wiper

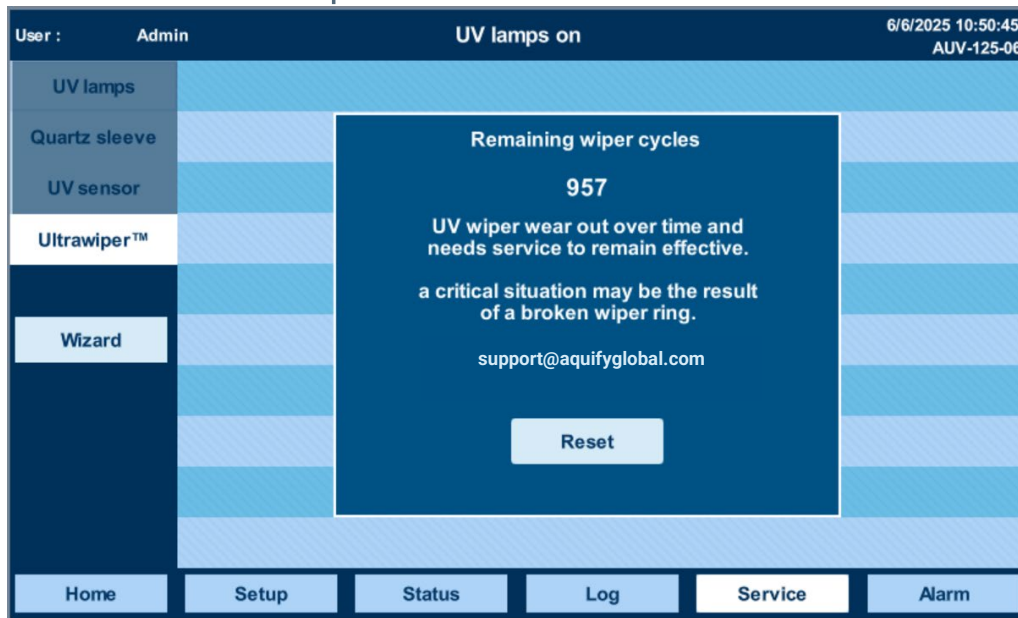

The wiper lifetime counter is based on the number of cycles rather than hours.

Service is recommended once the wiper completes 1,000 cycles; however, the exact service interval may vary significantly depending on water quality. Poor water quality leads to faster fouling on the quartz sleeves, which, in turn, causes increased wear on the wiper rings. In environments with higher contaminant levels, more frequent servicing may be necessary to maintain optimal performance.

TROUBLESHOOTING

Do I have the correct UV intensity?

UV intensity depends on water transparency and temperature and will be different for each set-up. Use the maintenance table to observe the UV intensity over time.

Example of UV intensity:

Pool water containing free and combined chlorine with a measured UVT of 97.7% and a temperature of 81°F/27°C have a measured UV intensity of $\approx 900\text{W}/\text{m}^2$ after 45 min runtime with a single 600W lamp.

Does the system give an alarm with too low UV intensity?

No, since UV intensity depends on water transparency and temperature. Therefore, it will be different for each set-up.

Use the maintenance table to observe possible changes in the UV intensity over time, see section of “Low UV-intensity” to find a possible solution to the problem.

What alarm does the system give?

The system gives an alarm if the temperature of the system exceeds 113°F/45°C and if the circuit to the lamp(s) is

broken. In both cases, the system will shut down.

See the section “Alarm Messages” to find a possible solution to the alarms.

Why is the system leaking at the quartz sleeve?

If the system is leaking around the quartz sleeve, check if the correct O-rings have been used and have been lubricated and tighten the ends more.

Order O-rings and lubrication at Aquify.

Fouling on quartz sleeve and/or sensor

Clean or replace the quartz sleeve by removing it from the reactor, remember to empty the system for water. Contact Aquify for ordering replacement kit.

Water transmissivity has decreased

Check the UVT value of the water. Water samples can be sent to Aquify for determination of UVT or order a UVT instrument.

Lifetime of the lamp(s) has exceeded

The lifetime of a lamp is 9,000 hours. Change the lamp. Contact Aquify for ordering replacement kit.

Inaccurate UV sensor readings

Check if the sensor head is dry and clean else replace the sensor by ordering a sensor and replacement kit.

Wrong lamp type

Lamp type must be applicable to the system, single end.

Low power level

Check the power supply.

ALARM TABLE

ALARM TEXT	EFFECT	TRIGGER	CORRECTIVE ACTION	SPECIAL NOTE
General alarms				
Temperature inside cabinet is too high!	No shutdown	Temperature inside the cabinet exceeds the setpoint of relay.	Increase airflow inside the cabinet. Adjust setpoint of temperature relay.	
Temperature is reaching high level.	No shutdown	Temperature has exceeded setpoint of pre-alarm.	Check for air pockets inside the reactor. Adjust alarm setpoint.	To reset the alarm the temperature must be 3°F/ 2°C below setpoint.
Temperature inside cabinet is too high! System shut down.	Immediate shutdown	Temperature has exceeded setpoint of temperature alarm.	Check for air pockets inside the reactor. Adjust alarm setpoint.	To reset the alarm the temperature must be 3°F/ 2°C below setpoint.
System has been started and stopped too often.	No shutdown	System has been started more than default setpoint of 10x per/day.	Reset the alarm and startup is possible again.	
Enable safety circuit 1 has been broken.	Delayed shutdown	The 24V safety circuit has been broken.	Close the safety circuit.	
Enable safety circuit 2 has been broken.	Delayed shutdown	The 24V safety circuit has been broken.	Close the safety circuit.	
UV sensor alarms				
UV Intensity has reached alarm limit.	No shutdown	The UV Intensity has decreased to alarm setpoint.	Check UV sensor, check UV sensor housing and glass, confirm the wiper brush is cleaning housing. Check water quality.	
UV Intensity has reached pre- alarm limit. UV Intensity is 0.	No shutdown	The UV Intensity has decreased to pre- alarm setpoint.	Check UV sensor, check UV sensor housing and glass, confirm the wiper brush is cleaning housing. Check water quality.	
Action must be taken.	No shutdown	The UV Intensity has reached 0.	Check UV sensor, check UV sensor housing and glass, confirm the wiper brush is cleaning housing.	For this alarm to trigger the UV intensity must be 0 for 25 seconds.
UV Sensor 1 has lost communication.	No shutdown, flow not allowed	UV Sensor 1 has lost communication.	Check UV sensor connection and sensor cable	
Wiper alarms				
Wiper has taken too long in its current cycle.	No shutdown, wiper stopped	Wiper has taken longer to complete a cycle than the entered time setpoint.	Check wiper faults. Check wiper path for any obstacles.	
Wiper has lost 24V power supply.	No shutdown, wiper stopped	Wiper has lost its 24V power supply and cannot operate.	Check wiper power supply in cabinet. Check motor card wiring.	
Wiper has met too high resistance.	No shutdown, wiper stopped	Wiper has met too high resistance and shutdown due to motor over current.	Check wiper path for any obstacles. Check cleanliness of quartz sleeves. Adjust interval of wiper cycles.	In cases where motor keeps faulting on over current, contact Aquify support.
Wiper has counted more pulses than necessary.	No shutdown, wiper stopped	When wiper reached home position, the pulse counter was higher than 2.	Check wiper assembly.	
Wiper is rotating but not counting pulses.	No shutdown, wiper stopped	The motor is rotating but not counting pulses.	Check pulse sensor. Check pulse sensor position. Check pulse sensor wiring.	
UV Dose alarms				
UV Dose is reaching low setpoint.	No shutdown	The UV Dose has reached pre- alarm setpoint.	Check UV sensor, check UV sensor housing and glass, confirm the wiper brush is cleaning housing. Check flow rating and current flow. Check water quality.	The UV Dose is calculated on basis of UV intensity and flow and therefor is always related to these issues.
UV Dose has reached critically low setpoint.	No shutdown, flow not allowed	The UV Dose has reached alarm setpoint, action must be taken.	Check UV sensor, check UV sensor housing and glass, confirm the wiper brush is cleaning housing. Check flow	The UV Dose is calculated on basis of UV intensity and flow and therefor is always related to these issues.

rating and current flow. Check water quality.

ALARM TEXT	EFFECT	TRIGGER	CORRECTIVE ACTION	SPECIAL NOTE
Driver and lamp fault				
Driver Fault.	Lamp shutdown		Check error code.	To see the specific alarm of the driver, go to "Driver Status" screen.
Lamp Fault.	Lamp shutdown		Check error code.	To see the specific alarm of the lamp, go to "Lamp Status" or "Driver Status" screen.
Driver Com Fault.	Lamp shutdown	Driver lost communication with PLC.	Check communication wiring to driver.	
Maintenance alarms				
Wiper requires service soon.	No shutdown	Remaining wiper cycles is less than 100.	Consider ordering spare parts and/or scheduling of service from Aquify.	
Wiper requires service now.	No shutdown	Remaining wiper cycles is 0.	Service is strongly recommended. Consider ordering spare parts and/or scheduling of service from Aquify.	
UV lamps require replacement soon.	No shutdown, reduced efficiency	Remaining operating hours on UV Lamps is less than 1,000 hours.	Consider ordering spare parts and/or scheduling of service from Aquify.	
UV lamps require replacement now.	No shutdown, reduced efficiency	Remaining operating hours on UV Lamps is 0.	Service is strongly recommended. Consider ordering spare parts and/or scheduling of service from Aquify.	
Quartz sleeves require replacement soon.	No shutdown	Remaining hours of Quartz sleeve counter is less than 1,000 hours.	Consider ordering spare parts and/or scheduling of service from Aquify.	
Quartz sleeves require replacement now.	No shutdown	Remaining hours of Quartz sleeve counter 0.	Service is strongly recommended. Consider ordering spare parts and/or scheduling of service from Aquify.	
UV sensor requires replacement/recalibration soon.	No shutdown, reduced efficiency	Remaining operating hours of UV sensor is less than 1,000 hours.	Consider ordering spare parts and/or scheduling of service from Aquify.	
UV sensor requires replacement/recalibration now.	No shutdown, reduced efficiency	Remaining operating hours of UV sensor 0.	Service is strongly recommended. Consider ordering spare parts and/or scheduling of service from Aquify.	

ERROR & WARNINGS

The error & warning state, type and ID is a number with 4 or 5 digits and have the following format:

- Error number (Register 70): XXYZZ
- Warning number (Register 72): XXWW
- XX= State, Y= Error Type, ZZ = Error ID and WW= Warning ID

Error and warning numbers build like this:

- Error number= $XX*1000 + Y*100 + ZZ$
- Warning number= $XX*100 + WW$

XX	STATE	Y	ERROR TYPE	REMARK
1	Powerup Unit	0	None	
2	IDLE	1	Powerup unit check	
3	Ignition	2	IDLE check	
4	Ignition Cooldown	3	Fast check	
5	Warmup	4	Half cycle check	
6	Run	5	Slow 1sec check	
7	Input Undervoltage	6	Slow 1min check	
8	Error	7	CLA	CLA errors have their own ID (Table 4)
9	Powerup Error	8	Other	
10	Secondary Error	9	Secondary	Secondary errors have their own ID (Table 5)
11	Pre-Ignition	<i>Table 2 Y=Error type</i>		
12	Bootstrap			
13	Series/Parallel initialization			
14	Reset sanity fault			
15	Sanity faults are reset			

Table 1 XX=State

ZZ	CLA ERROR ID
0	None
1	Current paths to many
2	Current paths to few
3	Vign high
4	Cext to high
12	lout high
13	Fast check Phase error
17	Cext calc. failed
18	Ignition duration exceeded
19	Follower Sync Signal out of range during Ignition
20	Follower Sync Signal out of range during Run
21	Sync amplitude POS
22	Sync amplitude NEG

Table 4 ZZ=CLA Error ID

ZZ	ERROR TYPE
0	None
1	No communication
2	12V ISO Low CMP
3	Fan current Trip
4	12V ISO Low ADC

Table 5 ZZ=Secondary Error ID

ZZ	WARNING ID
10	Power below setpoint (setpoint=95% of the power as set by "Dim level" and "max lamp power")

Table 6 WW=Warning ID

MAINTENANCE

The maintenance is divided into monthly, annually and every 3rd year. For tracking the process, a maintenance table is attached to this manual on page 60. Spare parts for annually and every 3rd year can be ordered as replacement kits with an adjacent instruction manual.



UV RAYS!

Protect eyes and skin.



WEAR GLOVES

When handling the UV lamps and quartz sleeves.



HIGH VOLTAGES!

Shut down system during maintenance.

MONTHLY

Record operation hours counter value	USE TABLE
Check UV sensor is clean	USE TABLE
Record UV sensor intensity	USE TABLE
Clean cabinet fan filter	USE TABLE

YEARLY

Replace UV lamp**	USE TABLE
Check wiper ring and wiper nut	USE TABLE
Check and replace sacrificial anode if necessary	USE TABLE
Replace the UV sensor	USE TABLE
Check wiper spindle seal for leakage and wear and replace if necessary	
NOTE: Always replace wiper spindle seal after 500 cycles or after one year, whichever comes first.	USE TABLE

EVERY 3RD YEAR

Replace quartz sleeve	
-----------------------	--

* Interval for sensor cleaning depends on water quality.

** Lamp should be replaced every year or at (9,000 hours). Burning hours and start/stop wears the lamp out. End of lamp time is when the ultraviolet light has decreased to around 50% and energy consumption is too high per produced UV ray. Dimming will not extend lamp lifetime.

DISPOSABLE



MAINTENANCE TABLE

Disconnect the system from the main power supply and/or switch off the main switch before any maintenance work on the system. Always depressurize the reactor before any service work. There is a risk of serious injuries. Quartz sleeves or pieces of broken quartz sleeves can be blown out of the reactor.

An automatic cleaning system should be serviced if measured values of intensity are dropping due to fouling of the quartz sleeves. Pull out the quartz sleeve and the UV sensor, before disassembly and check for fouling. If both appear clean there is no reason to dismantle the system, and the operation should be postponed.

Fill out the table below with the observed hour count before carrying out a replacement.

MONTHLY MAINTANCE LOG						
Date:						
Record Total hours						
No leakage observed						
Clean cabinet filter						
Tighten cable glands						
Check UV sensor is clean						
Record UV sensor intensity						

ANNUAL MAINTANCE LOG						
Date:						
UV Lamp						
UV Sensor O-Rings						
Quartz sleeve						
Wiper ring						
Spindle sealing						
Sacrificial anode						

3 YEAR MAINTANCE LOG						
Date:						
Check Quartz Sleeve						

UV lamp max. 9,000 hrs.
 Quartz sleeve max. 25,000 hrs.

****NOTE:**** ALWAYS REPLACE O-RINGS WHEN REPLACING QUARTZ SLEEVE

WEAR GLOVES

When handling the UV lamps and quartz sleeves



SPARE PARTS

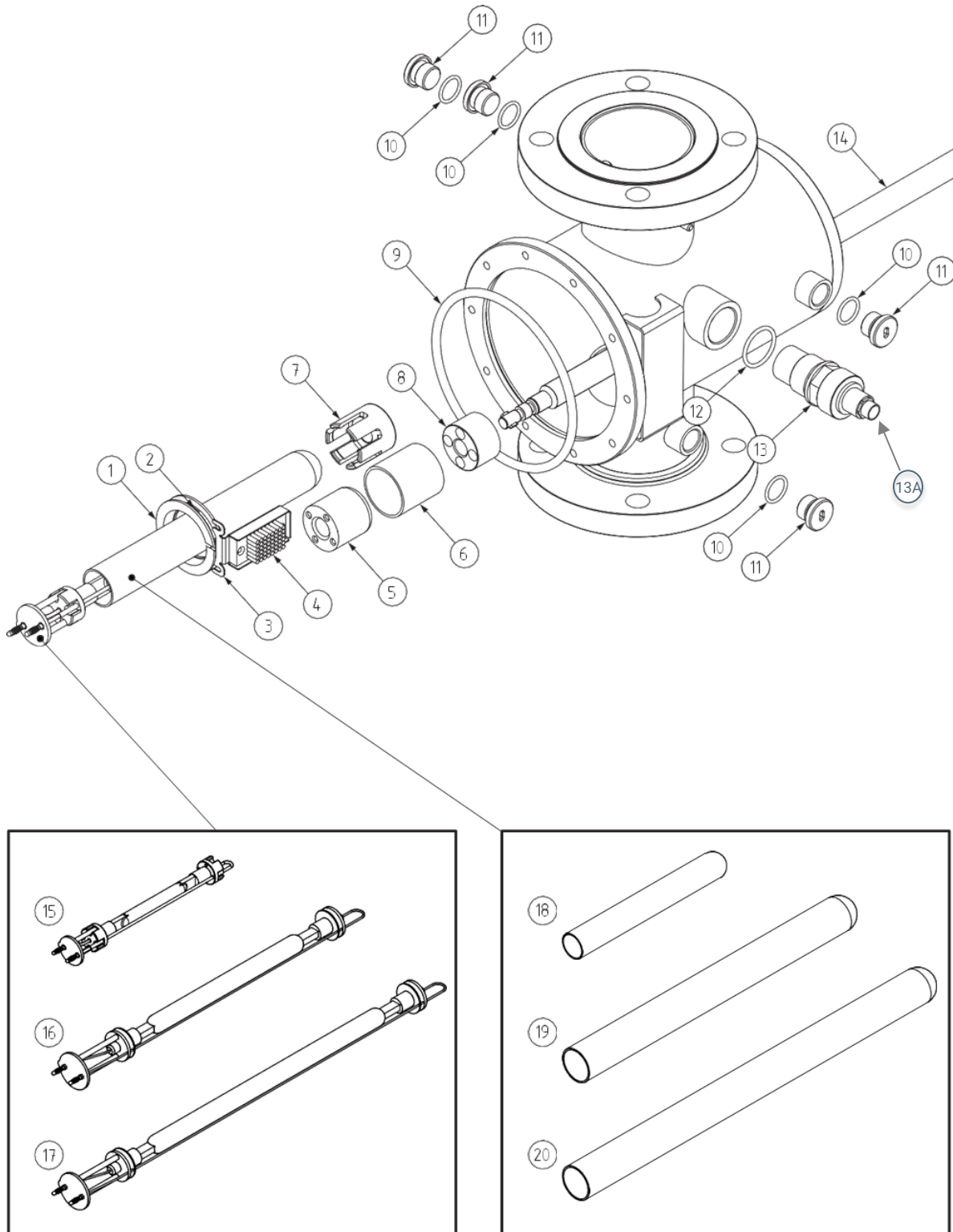

Model Key

- AUV-106-03 = 03
- AUV-206-04 = 04
- AUV-125-06 = 06
- AUV-225-08 = 08
- AUV-240-10 = 10
- AUV-340-12 = 12

PART NUMBER	PART NAME	MODEL
1150-U005	Assembly Wiper Ring PTFE D33	03, 04
	[1] MP Wiper Ring PTFE D33 G3	
	[2] O-Ring 38,0x3,5-F75 (MP Wiper Ring)	
1150-U006	Assembly Wiper Ring PTFE D44	06, 08, 10, 12
	[1] MP Wiper Ring PTFE D44 G3	
	[2] O-Ring 44,04x3,53-F80 (MP Wiper Ring)	
3057-U008	[3] Wiper Brush Bracket	All
6540-U001	[4] LP-MP Brush for sensor window FDA Approved - Soft fibers	All
6530-U003	[5] Wiper Spindle Nut - Small	All
	[6] Spindle Nut protection pipe OD44,5x2,0 L45	All
3328-U011	[7] Quartz Base OD33	03, 04
3328-U014	Quartz Base OD44	06, 08, 10, 12
6530-U002	[8] Wiper Spindle Counter Bearing - Small	All
3B57-U101	O-Ring Reactor 145 N70	03, 06
3B57-U102	[9] O-Ring Reactor 194 N70	04, 08, 10
3B57-U103	O-Ring Reactor 247 N70	12
	[10] O-ring 19,0,4x2,5-F70 (Half inch plug)	All
3328-UH01	[11] Plug 1/2in NPT	All
1150-U003	Assembly LP UV Sensor Window	All
	[12] O-Ring 30,0x3,0-F70 (1 inch plug)	
	[13] LP UV Sensor Window ÖNORM LOW UVT	
7740-U002	[13A] Sensor UV 5000W m2 ÖNORM 4-20mA	All
3507-U012	Wiper Spindle 11in / 280mm SS316L	03, 04
3507-U013	[14] Wiper Spindle 19in / 480mm SS316L	06, 08
3507-U014	Wiper Spindle 24in / 6100mm SS316L	10, 12

PART NUMBER	PART NAME	MODEL
6510-U061	[15] Lamp MPUV DBP 600w-AL90 G2	03, 04
6510-U200	[16] Lamp MPUV DBP 2500w-SE	06, 08
6510-U400	[17] Lamp MPUV DBP 4000w-SE	10, 12

PART NUMBER	PART NAME	MODEL
6520-U060	[18] Quartz Sleeve 600w L244mm OD33mm	03, 04
6520-U200	[19] Quartz Sleeve 2500w L450mm OD44mm	06, 08
6520-U400	[20] Quartz Sleeve 4000w L579mm OD44mm	10, 12

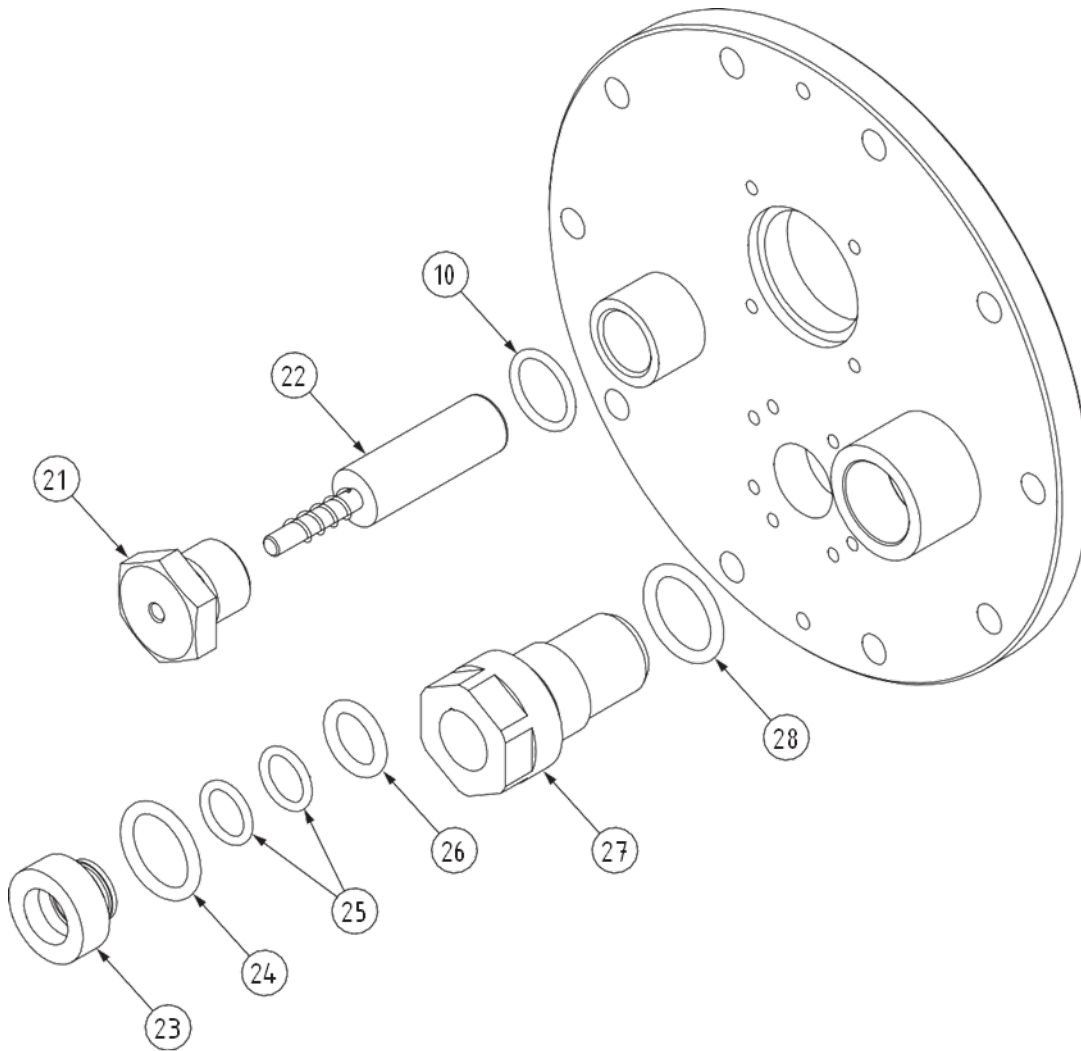

PART NUMBER	PART NAME	MODEL
1150-U004	Assembly Plug 1/2in NPT for Anode	All
	[10] O-Ring 19,0,4x2,5-F70 (Half inch plug)	
	[21] Plug for Anode - half inch BSP	
	[22] Zinc Anode OD17x50 M6x32	
1150-U007	Assembly Wiper Spindle Seal	All
	[23] Wiper spindle seal UA design	
	[24] O-Ring 22,0x3,50-F80 (wiper spindle seal)	
	[25] O-Ring 14,0x2,5-N90 FDA app. (wiper spindle seal)	
	[26] O-Ring 15,47x3,53-N70 FDA app. (wiper spindle seal)	
1150-U008	Assembly Wiper Proximity House	All
	[27] Wiper Proximity Sensor House 3/4"	
	[28] O-Ring 23,5x2,5-F70 (Three quarter inch plug)	

TESTING AND COMMISSIONING – SIGN OFF

Each UV system undergoes pressure testing, electrical testing, and leakage control testing before packing. These quality assurance steps ensure that the system meets performance standards, operates safely, and maintains structural integrity.

Upon receiving the UV system, inspect it carefully for any potential damage sustained during shipping. If any damage is detected, take photo documentation and immediately contact Aquify or a certified Aquify support agent.

As part of the commissioning process, Aquify Systems and the End-Customer (_____) acknowledges and will sign-off on the following items to confirm successful installation and readiness for operation:

- The cabinet is in a dry environment and enables the airflow to be operational.
- The UV reactor is installed according to the manual – Horizontally. If air pockets are expected, air bleed must be considered.
- Additional leakage testing on site.
- Go through relevant parameters (flow rate, dose requirements, etc.)
- The wiper has been operated for a full cycle, without any concerns.
- The temperature sensor reads a value corresponding to logical assessment.
- The lamp(s) ignites successfully.
- The UV sensor reads a UVI.
- Functionality testing and walkthrough was performed.
- The manual is available and has been reviewed, and the End-Customer has been instructed to read – and record continuous measurements, which can be noted in “Maintenance Table” found on page 63.

Important to ****NOTE:****

Use gloves, when in contact with quartz sleeves and lamps.

Ensure no alcohol or water will enter the inside of the quartz sleeve. If so, it will need to be dry prior to operation.

Water entering the UV system may not contain iron.

I, (INSERT NAME), hereby sign and acknowledge that Aquify UV system, reference (job name & body of water) with serial number _____ is operating as intended, according to the above.

CUSTOMER: _____

Aquify Systems or Aquify Certified Representative

Title: _____

Title: _____

By: _____

By: _____

Date: _____

Date: _____

EQUIPMENT WARRANTY

Warranty of Coverage:

The following warranty applies for Aquify Systems UV

Equipment Period of Coverage:

Aquify Systems (“AQUIFY”) warrants to the Owner/Operator noted above (the Customer) that if within 12 calendar months from equipment ship date after commencement of operation, provided that the Customer has signed and returned to the Testing and Commissioning – Sign Off, that the equipment (excluding consumables) is guaranteed for a period of five (5) years. The equipment must be maintained and documented utilizing the operator’s log and maintenance records and serviced annually by a factory trained and certified AQUIFY representative as outlined in the Operation and Maintenance Manual using original manufacturers parts. Failure to service the system as described above and/or utilize factory-approved parts will negate the warranty. With no Testing and Commissioning – Sign Off the warranty period is (1) One Year.

Customer must notify AQUIFY in writing within 5 days of the date of any Equipment failure. This notification shall include a description of the problem, a copy of the operator’s log, a copy of the Customer’s maintenance record and any analytical results detailing the problem.

If Customer has not maintained the operator’s log and maintenance record in the manner directed in the Operation and Maintenance Manual or does not notify AQUIFY of the problem as specified above, this warranty may, in AQUIFY’s discretion, be invalid.

If a defect occurs, AQUIFY will, at our option, repair or replace the defective component free of charge, provided that:

- Customer fully cooperates with AQUIFY, in the manner requested by AQUIFY, in attempting to diagnose and resolve the problem by way of phone and email service support.
- If the problem can be diagnosed and verified by telephone support and a replacement part is required, AQUIFY will either ship at AQUIFY’s expense, a repaired, reworked or new part to the Customer, who will install such part as directed by AQUIFY or direct Customer to acquire, at AQUIFY’s expense, such part from a third party and to install such part as directed by AQUIFY.
- In the event that AQUIFY determines that the problem cannot be resolved by way of telephone support and/or shipment by AQUIFY, or acquisition by the Customer of a replacement part for installation by the Customer, AQUIFY will send one or more persons to make an onsite inspection of the problem. If an onsite visit is made, AQUIFY’s personnel will evaluate the problem and repair or replace any Equipment determined to be in warranty. If the problem is determined to be attributed to a breach of this warranty, AQUIFY reserves the right to invoice the Customer for this service.
- The Equipment is covered, and the failure occurs within the Warranty Period.

AQUIFY will, at its option, use new and/or reconditioned parts in performing warranty repair. AQUIFY has the right to use parts or products of original or improved design in the repair or replacement.

The products or general components replaced or repaired free of charge under the Equipment Limited Warranty are warranted only for the remaining portion of the original Equipment Limited Warranty Period.

Limitations: This warranty shall not apply to any failure or defect which results from:

- The Equipment not being operated and maintained in strict accordance with instructions specified in the Operation and Maintenance manual or Product Bulletin or which results from mishandling, misuse, neglect, improper storage, improper operation of the Equipment with other equipment furnished by the Customer or by other third parties or from defects in designs or specifications furnished by or on behalf of the Customer by a person other than AQUIFY.
- Equipment that has been altered or repaired after start-up by anyone except: (a) authorized representatives of AQUIFY, or (b) Customer acting under specific written instructions from AQUIFY.
- Use of parts not supplied or approved by AQUIFY.

This warranty does not cover:

- Equipment components manufactured by third parties but furnished to Customer by AQUIFY are warranted by the original manufacturer, only to the extent of the original manufacturer's warranty.
- Normal wear and tear of the product.
- Consumable components including but not limited to wiper rings, any O-rings, batteries AQUIFY supplied components that are the subject of a separate warranty.
- Costs related to removal, installation, or troubleshooting of the damaged component.
- Improper installation.
- Acts of God, terrorism, biological infestations, or input voltage that create operating conditions beyond the minimum or maximum limits listed in the Operations Manual including high input voltage from generators and lightning strikes.
- Damage caused by improper return packaging Taxes, duties or brokerage fees (if any).

This warranty is the exclusive remedy for all claims based on a failure of or defect in the Equipment, whether the claim is based on contract (including fundamental breach), tort (including negligence), strict liability or otherwise. This warranty is in lieu of all other warranties whether written, oral, implied or statutory. Without limitation, no warranty of merchantability or fitness for a particular purpose shall apply to the Equipment.

AQUIFY does not assume any liability for personal injury or property damage caused by use or misuse of the Equipment. AQUIFY shall not in any event be liable for special, incidental, indirect or consequential damages including, without limitation, lost profits, lost business opportunities, lost revenue or loss or depreciation of goodwill, even if it has been advised of the possibility thereof. AQUIFY's liability shall, in all instances, be limited to repair or replacement of Equipment in breach of this warranty and shall not exceed the cost of such repair or replacement. This liability with respect to repair or replacement will terminate upon the expiration date of this warranty.

In addition to the foregoing, in no event shall AQUIFY's liability relating to the Equipment, or the agreement between AQUIFY and the Customer relating to the Equipment, exceed that portion of the purchase price for the Equipment which is actually paid to AQUIFY.

LAMP WARRANTY

Warranty of Coverage:

The following warranty applies to Aquify Systems (“AQUIFY”) Medium Pressure High Intensity UV Lamps (the “Lamps”) for the AQUIFY AUV Series.

Validity:

The warranty is only valid with respect to a Lamp that is properly stored, handled and installed as specified in the Operation and Maintenance manual supplied with the system in which the Lamp is installed or as outlined in subsequent Product specifications. Without limiting the generality of the foregoing, any excess vibration or improper operation of a Lamp shall void this warranty. In addition, AQUIFY shall not be liable for any Lamp failure which results from UV equipment not being operated and maintained in strict accordance with the instructions set out in the Operation and Maintenance manual or as outlined in Product specifications.

Lamp Warranty Claim:

In order to process any Lamp warranty claim, AQUIFY requires the Customer to provide a copy of the operator’s log, all maintenance records and a complete warranty claim for the local distributor/AQUIFY within one (1) month of the lamp failure. Failure to meet these terms will void the Lamp warranty.

AQUIFY reserves the right to require the Customer to return a failed Lamp to AQUIFY facilities for inspection. Failure to return the Lamp when requested shall void the warranty.

Period of Coverage:

When a Lamp has been stored, handled and installed as specified in the Operation and Maintenance manual or as outlined in Product specifications, and the relevant UV equipment has been operated and maintained in accordance with instructions specified in the Operation and Maintenance manual, and:

1. The Lamp fails within the first 2,000 hours of operation; AQUIFY shall provide the Customer with a replacement Lamp free of charge.
2. The Lamp fails after 2,000 hours and prior to 9,000 hours of operation; AQUIFY shall provide the Customer with a replacement Lamp at a discounted price. The following formula is used to determine the discounted price for the replacement Lamp:

$$\text{Replacement Lamp Price} = ((\text{Lamp Operating Hours}) / 9,000 \times \text{Lamp List Price})$$

Regardless of actual Lamp operating hours, the Lamp warranty is void if the date of Lamp failure occurs more than thirty-six (36) calendar months after the Lamp shipment date from AQUIFY.

The above operating conditions of Lamps are based on an average of 4 On/Off cycles, per 24-hour period, accumulated over the total guaranteed life of the Lamp.

Limitations:

This limited warranty does not cover:

- Lamps that have been used with parts not supplied or approved by AQUIFY
- Lamps that have been physically damaged or fail due to corrosion, exposure to contaminants (e.g. effluent), incorrect installation or operation
- Costs related to troubleshooting, removal, or installation
- Return damage caused by improper packaging
- Taxes, duties or brokerage fees (if any)

The above warranty is the exclusive remedy for all claims based on a failure of or defect in a Lamp, whether the claim is based on contract (including fundamental breach), tort (including negligence), strict liability or otherwise. This warranty is in lieu of all other warranties whether written, oral, implied or statutory. Without limitation, no warranty of merchantability or of fitness for a particular purpose shall apply to a Lamp.

AQUIFY does not assume any liability for personal injury or property damage caused by use or misuse of a Lamp. AQUIFY shall not, in any case, be liable for special, incidental, indirect or consequential damages, even if it has been advised of the possibility thereof. AQUIFYs' liability shall not, in any case, exceed the cost of replacement of a defective Lamp.

ANNEX

Validation Specification:

The tests were conducted in water with UVT254 conditions of 94% and according to NSF/ANSI/CAN 50-2024 requirements.

OBERVED LOG REDUCTIONS		
Description	<i>E. faecium</i>	<i>P. aeruginosa</i>
1 st turnover	4.6	4.4
2 nd turnover	5.1	4.7
3 rd turnover	5.1	4.5
4 th turnover	6.1	4.7
5 th turnover	6.1	5.2

**Above achieved with the following flow rates:

Model	Max Flow [gpm]	Disinfection	End Use
AUV-106-03	125	Supplemental	Pool or Spa/Hot Tub
AUV-206-04	350	Supplemental	Pool or Spa/Hot Tub
AUV-125-06	645	Supplemental	Pool or Spa/Hot Tub
AUV-225-08	1,530	Supplemental	Pool or Spa/Hot Tub
AUV-240-10	2,200	Supplemental	Pool or Spa/Hot Tub
AUV-340-12	3,120	Supplemental	Pool or Spa/Hot Tub

Aquify Systems

10550 Plano Rd.
Dallas, Texas 75238
1.833.386.2782
www.aquifysystems.com

All Aquify Systems trademarks and logos are owned by Aquify Systems. Unless expressly noted, names and brands of third parties that may be used in this document are not used to indicate an endorsement between the owners of these names and brands and Aquify Systems. Those names and brands may be the trademarks or registered trademarks of those third parties. Aquify reserves the right to change any information in this document without prior notice, and Aquify accepts no responsibility for any damages as a result of the use of any information contained in this document.

© 2022 Aquify Systems. All rights reserved. This document is subject to change without notice.

